

Heavy-Duty Shock Absorbers

HLS-70

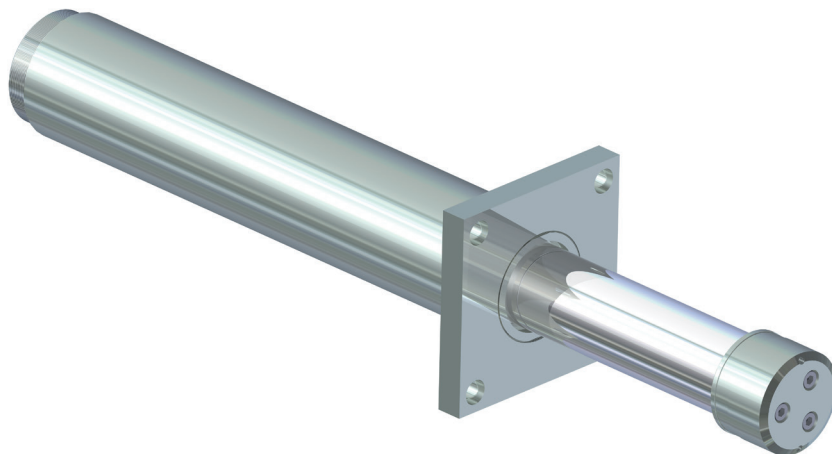

ONLINE
Calculation and
2D / 3D CAD Download

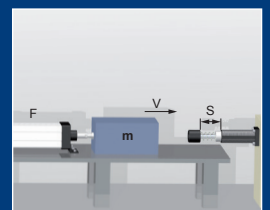

Operating Principle

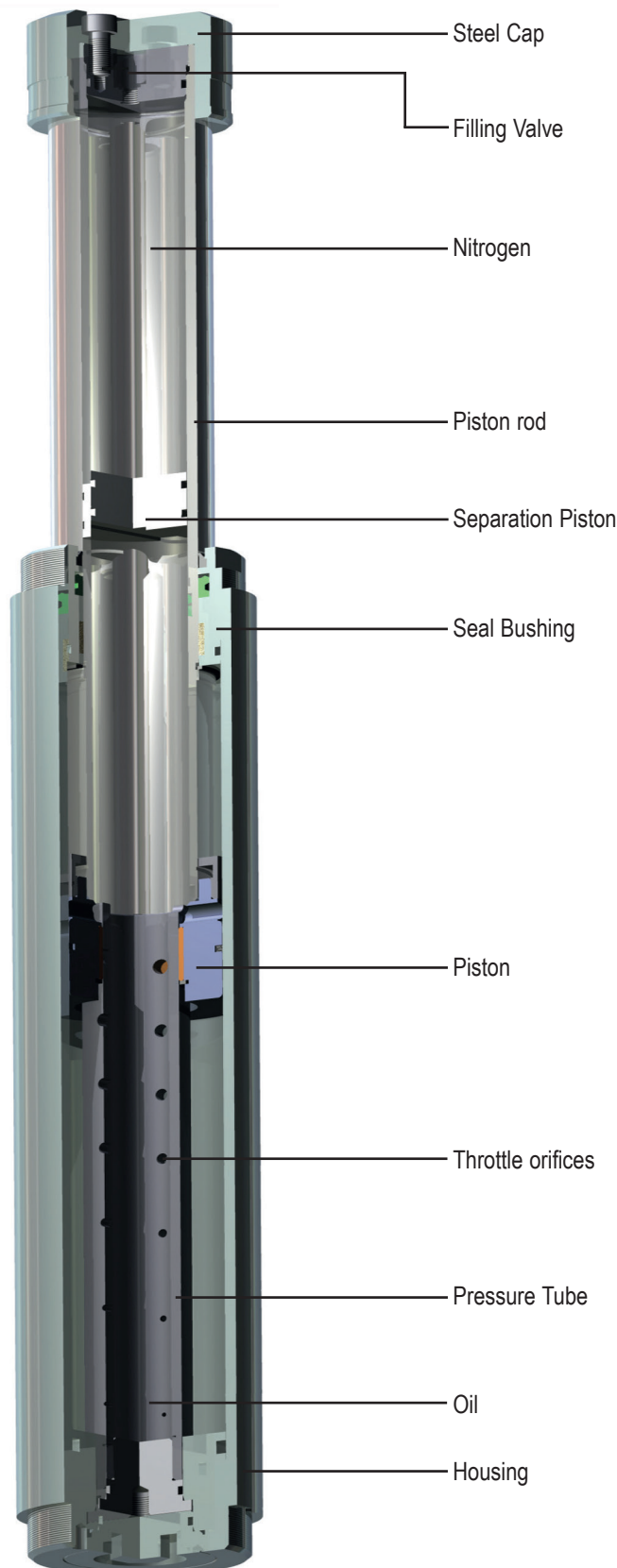

Operating Principle

HLS models have two chambers filled with hydraulic oil and nitrogen. The piston rod is used as an accumulator.

Under impact the piston rod is pushed into the cylinder displacing the oil through the orifices into the pressure tube, moving the separator piston towards the steel cap and compressing the nitrogen.

When the mass is released the pressure of the nitrogen sets back the piston rod.

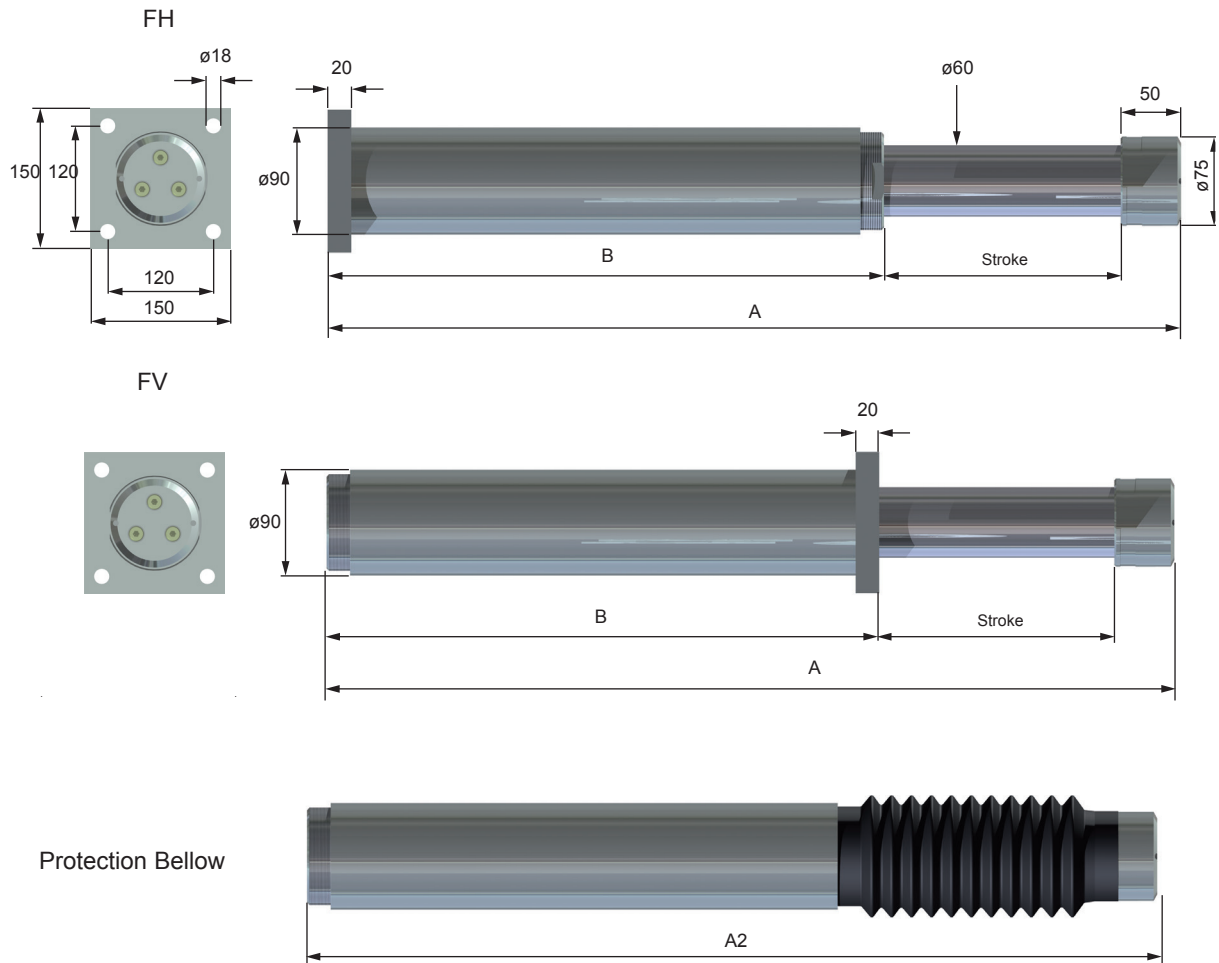

	Stroke	Energy/Stroke	max. Counterforce	Piston return force		max. angular tolerance	Weight	A	B	D	E	A2*
	mm	Nm	N	min. N	max. N	°	FV / FH kg	mm	mm	mm	mm	mm
HLS-70-050	50	10000	250000	1500	14000	2,5	13,5	329	229	261	84	355
HLS-70-100	100	20000	250000	1500	14000	2,5	14,0	440	290	322	134	466
HLS-70-150	150	30000	250000	1500	18000	2,5	15,5	585	385	417	184	611
HLS-70-200	200	40000	250000	1500	19000	2,5	17,0	720	470	502	234	746

Adjustment

The shock absorbers HLS-70 are non adjustable.

The shock absorber is calculated according to the technical designations of the customer and can be used then only for this application.

Features

Applications:

- Cranes, Swing bridges

Deceleration characteristics:

- Customer special

Coating:

- Standard:
Housing zinc plated
- Outdoor:
Housing and seal bushing painted
conforming to DIN ISO 12944-C5L
Piston rod: nickel (30 µm) and
hardchrome (20 µm) plated

Packaging:

- Wooden boxes
- Depending on national
regulations according to ISPM 15

RoHS-conform:

- Directive 2002/95/EC

Extended Life Cycle:

- Piston rod: hard chrome-plated
- Special Seals + Oils

Temperature:

- Standard: -20°C -...+80°C
- Low-temperature: -50°C-...+50°C
- High-temperature: 0°C-...+120°C

Instructions for use and assembly HLS

HLS series shock absorbers are delivered ready for installation

After receiving the shock absorbers, check for transport damage. This applies particularly for damage to the chrome finish on the piston rod. Before using, ensure that the part number in the order confirmation and on the shipping documents coincides with the number on the shock absorber.

Use the shock absorbers only as specified in the technical data, based on the design.

Always observe the following installation instructions:

- Ensure that shock absorbers are installed rigidly and vibration-free.
- Ensure that the stop surfaces are perpendicular to the stop cap and mounting flange
- Ensure that the mass is applied parallel to the damping direction and in the center of the stop cap/piston rod (see angle deviation in our catalog)
- The mounting bolts should not be more than 2 mm smaller than the intended mounting holes.
- Ensure that the shock absorbers are never subjected to direct or indirect distortion, because this would prevent the piston rod from moving.
- Protect the piston rod against damage
- From 800 mm stroke the shock absorber has to be mounted with foot mounting or with flanges at each side

We recommend to use a front flang mounting from 300 mm stroke.

For the HLS series is recommended for an easy maintenance to mount the damper so that the filling valve is at the top.

Heavy duty shock absorbers versions "FVFH" (2 flanges) and "FB" (foot mounting):

In these versions, the rear flange and the rear foot mounting are not glued in (status: 10.06.2009).

The shock absorber must be mounted free of tension. This is possible by twisting the rear flange if necessary.

Control: the shock absorber can be removed without tools after loosening the fastening screws.

For safety reasons we recommend the use of a security chain when the installation height of the HLS heavy-duty shock absorber is 2 m or above. The customer decides on the use.

Operating temperature (standard version): -20° C to max. +80° C;

Continuous operation (standard version): -10° C to max. +70° C;

Operating temperature (HT version): 0° C bis + 120° C;

Continuous operation (HT version): 0° C - +110° C

Operating temperature (LT version): -32° C to max. +60° C

Continuous operation (LT version): -32° C to max. +60° C

Operating temperature (LTT version): -50° C bis max. + 50° C;

Continuous operation (LTT version): -50° C bis max. + 50° C;

When used at low temperatures LT and LTT execution we recommend stationary installation; mobile mounting can result in leakage of the shock absorbers due to transfer of vibration!

Do not weld shock absorbers or subject to aggressive liquids. If shock absorbers are painted, ensure that the piston rod and the area where the piston rod enters the housing remain paint-free.

If it is not possible to maintain the above conditions, obtain written approval from Weforma Dämpfungstechnik GmbH before using.

If the piston rod does not extend by itself, the gas bladder can be filled through the pressure valve similar to a passenger car tire. Filling pressure: 6 bars/85 psi, Medium: Nitrogen, compressed air also possible.

The filling valve for gas is labelled "AIR" under the stop cap.

After an accident be sure to check the shock absorber for proper function and leakage. Otherwise perform this test once a year.

Design: Compression of piston rod in creep gear; after the load is relieved the piston rod should return to the original position.

Caution: The shock absorber is charged with gas at a pressure of 6 bars and should never be opened by customers. Risk of injury!

The current versions of our operating and installation instructions apply. These can be downloaded under www.weforma.com menu point Login/Service.

We reserve the right to make changes without further notice!

Important information

Attention!

Before Installation, commissioning, servicing and repair the date sheet is to be noticed. Realisation of the works only by trained, introduced specialist staff.

Electric connections according to the suitable national regulation.
for Germany: VDE regulation VD E0100

Before all repair, and servicing works the energy supplies (main switch, etc.) are to be switched off! Moreover, measures are necessary, around unintentional Reconnect to prevent, e.g., in the main switch a suitable warning „servicing works“, „repair works“ etc. attach.

Designated use

Check before installation and use whether the type name on the damper or on the packaging with the suitable name on the delivery note agrees

Industrial shock absorbers are maintenance-free and ready with installation

- Moved masses Can start with the installation of the shock absorbers by unintentional for injuries and body damages lead. Moved masses against unintentional procedure protect.
- The dampers can be inexpedient for the application and show no sufficient damping effect. Before the installation check the suitable suitability of the shock absorbers
- At the company beyond the allowed temperature area the damper can lose his function. To temperature area absolutely keep. Shock absorbers because of the warm radiotherapy do not varnish
- Fluide, gases and dirty particle in the surroundings can attack the poetry system of the shock absorber or destroy and lead to the functional financial loss of the shock absorber. Piston rod and poetry system against outside funds in the surroundings protect or isolate.
- Damages of the piston rod surface can destroy the Poetry system. Piston rod are not greasy, oil etc. and before dirty particles protect.
- the piston rod can be torn out from the damper. The piston rod do not load on train tension
- Shock absorber can break off in demand. The connection construction always lay out in such a way that the at most appearing forces with sufficient security can be recorded. The maximum supporting forces performed in the calculation programme can deviate from the later really appearing supporting forces, because these are based on theoretical values.
- A setting of the shock absorbers to the respective application is necessary compelling. A wrong setting of the damping leads to a raised machine charge and to an untimely financial loss of the shock absorber

Liability

Due to the number of possible uses of our products and the conditions of use that lie outside of our scope of influence, we accept no liability as to whether the purchase object is suitable for the Client's intended purpose. The verification to this effect, in particular the verification as to whether the purchase object is suitable for the planned use, is the responsibility of the Client alone, unless expressly agreed otherwise in writing.

For the reasons we accept no liability for the suitability of the purchase object for the purpose intended by the Client, except in cases of intent or gross negligence.

With damages, the not designated use and from high-handed, in these instructions do not originate to intended interventions, any guarantee and liability claim goes out towards the manufacturer.

Guarantee

By non-use of the original spare parts the guarantee claim goes out.

Environment protection

By the exchange from damaged parts is to be respected to a proper disposal.