

Shock Absorbers

Mega-Line WE-M 4,0

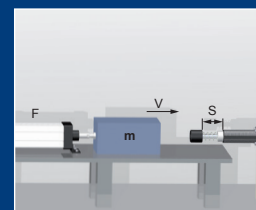

ONLINE
Calculation +
2D / 3D CAD Download



Benefits

Helix-Principle:

- Max. +300% Energy
- Max. -50% Costs / Nm

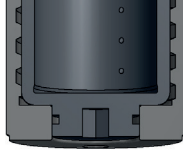

Pro Adjust:

- Protected adjustment



ProTec:

- Solid body without retaining ring

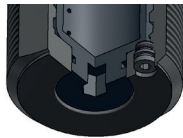

Piston:

- Hardened, Aluminium-Titanium-Nitride coated
- Special seals + oils

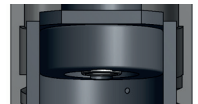

Extended life cycle:

- Nitrated guidance system

Integrated end stop:

- Max. security

Models:

- Black finish

Temperature:

Standard: -20°C-...+80°C

Low temperature: -50°C-...+60°C

High temperature: 0°C-...+120°C

Special edition :

- ProSurf
- V4A(/DIN1.440/AISL 316L)
- For pressure chambers up to 7 bar
- USDA-H 1 compliant for food industry
- Cleanroom

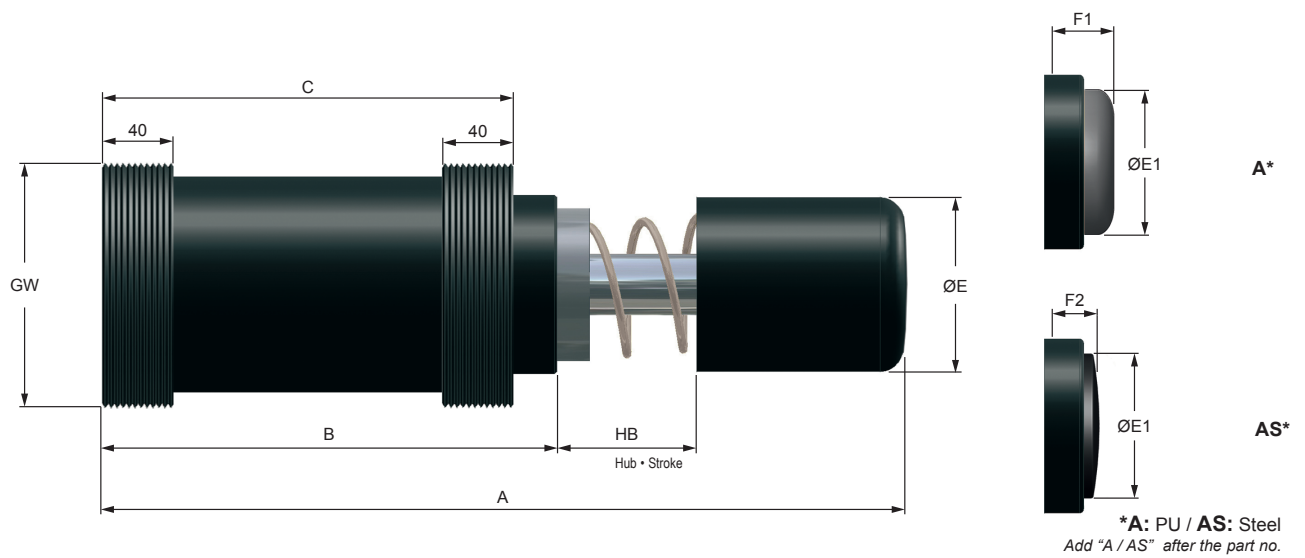

DIMENSIONS

	GW	A	B	C	ø E	ø E1	F1	F2
	Standard	mm	mm	mm	mm	mm	mm	mm
WE-M 4,0 x 2	M 115 x 2	319	225	205	80	66	25	15
WE-M 4,0 x 4	M 115 x 2	419	275	255	80	66	25	15
WE-M 4,0 x 6	M 115 x 2	569	325	305	80	66	25	15
WE-M 4,0 x 8	M 115 x 2	669	375	355	80	66	25	15
WE-M 4,0 x 10	M 115 x 2	769	425	405	80	66	25	15

PERFORMANCE

	Stroke mm	Energy absorption			Effective mass			
		Constant load*	Nm/h (max.)	External tank**	-1 (soft)	-2 (medium)	-3 (hard)	-4 (very hard)
		Nm/HB (max.)			Nm/h	min. - max.kg	min. - max.kg	min. - max.kg
WE-M 4,0 x 2	50	4000	1200000	1500000	280 - 89000	-	-	-
WE-M 4,0 x 4	100	9000	1800000	2250000	600 - 112500	-	-	-
WE-M 4,0 x 6	150	14000	2100000	2625000	925 - 175000	-	-	-
WE-M 4,0 x 8	200	19000	2660000	3325000	1250 - 237500	-	-	-
WE-M 4,0 x 10	250	24000	2880000	3600000	1580 - 300000	-	-	-

Technical data at + 20°C

Technical Data

Weight	4,0 x 2:	10 kg
	4,0 x 4:	12 kg
	4,0 x 6:	15 kg
	4,0 x 8:	18 kg
	4,0 x 10:	23 kg
Impact speed	WE-M:	0,02 - 6,0 m/s
Return spring force	4,0 x 2:	120 N/min - 200 N/max
	4,0 x 4:	120 N/min - 250 N/max
	4,0 x 6:	170 N/min - 250 N/max
	4,0 x 8:	170 N/min - 250 N/max
	4,0 x 10:	170 N/min - 280 N/max
Housing	Black finish	
Piston rod	Hardened stainless steel	
RoHS - compliant	Directive 2002/95/EG	

Accessories

Lock nut

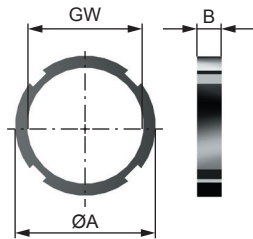

GW	Ø A (mm)	B (mm)
M 115 x 2	127	15

Code.: S27012

Stop limit nut

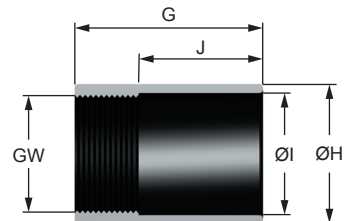

	Code	GW	G (mm)	Ø H (mm)	Ø I (mm)	J (mm)
4,0x2 - 4,0x4	S27018	M115x2	106	130	110	66
4,0x2A - 4,0x4A	S27018A	M115x2	131	130	110	91
4,0x6 - 4,0x10	S27218	M115x2	156	130	110	116
4,0x6A - 4,0x10A	S27218A	M115x2	181	130	110	141

Square flange

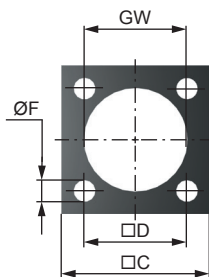

GW	C	D	Ø F	T
	mm	mm	mm	mm
M 115 x 2	140	111	17	25

Code.: S27014

Foot mounting

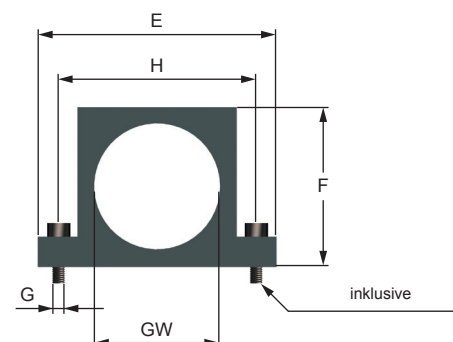
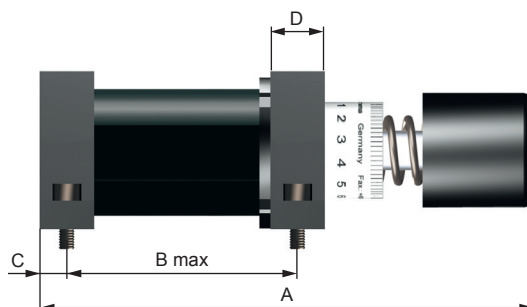

Code: S27015

	GW	A	B max	C	D	E	F	G	H
		mm	mm	mm	mm	mm	mm	mm	mm
4,0 x 2	M 115 x 2	319	180	12,5	25	203	149	M16x80	165
4,0 x 4	M 115 x 2	419	230	12,5	25	203	149	M16x80	165
4,0 x 6	M 115 x 2	569	280	12,5	25	203	149	M16x80	165
4,0 x 8	M 115 x 2	669	330	12,5	25	203	149	M16x80	165
4,0 x 10	M 115 x 2	769	380	12,5	25	203	149	M16x80	165

Clevis mounting on demand

Adjustment:

The adjustment can be done with the hexagonal recess in the bottom of the housing or with the adjustment ring at the piston rod side.

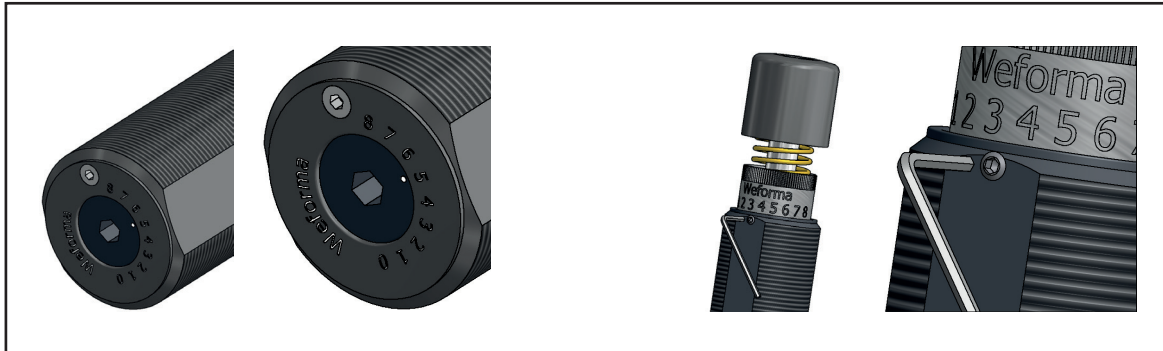

Adjustment: It is not allowed to adjust the shock absorber in operation conditions or during the operation.

0 = low damping
8 = high damping



In order to adjust the shock absorber set the adjustment screw to „6“ if the velocity is $<1,3$ m/s or to „4“ if the velocity is $>1,3$ m/s. Internal damage to the shock absorber can occur, if not adjusted in gradual increments. Do not drive in the final position under full load. If the damping is not sufficient, increase continuously by rotating the adjustment to the next higher number. Maximum damping is achieved, when the highest number on the scale is reached. If the mass impacts excessively hard on the shock absorber (stop cap) the damping should be reduced by rotation of the adjustment to the next smaller number. Minimum damping is at „0“ setting. Secure the adjustment with the threaded pin. A hexagonal key is supplied for this purpose. For sizes 1,25 and bigger the threaded pin is on the flats in the region of the front adjustment.

Installation

Foot mounting

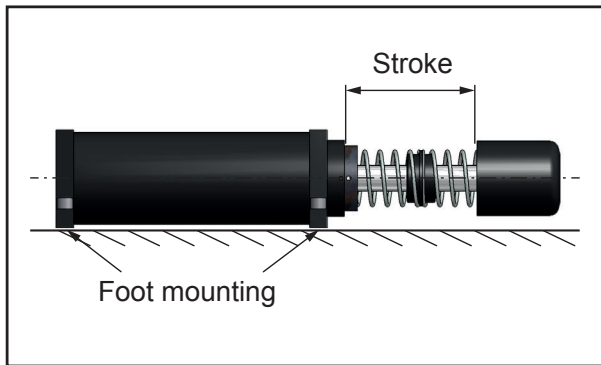

Instalaion with lock nut

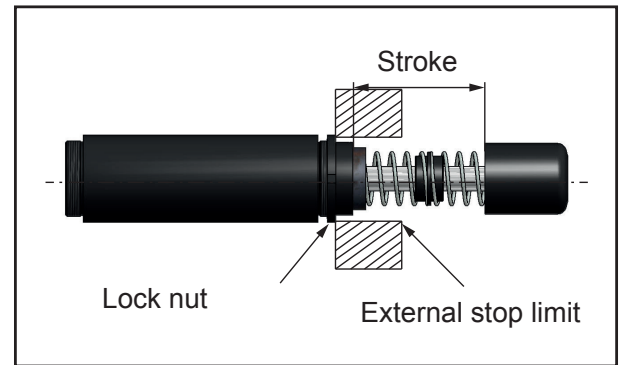

Installation with stop limit nut

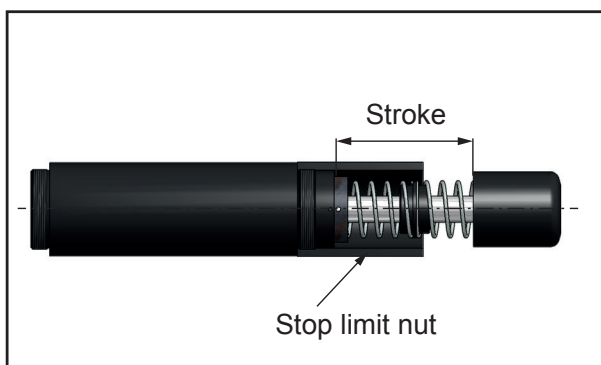

Installation with flange

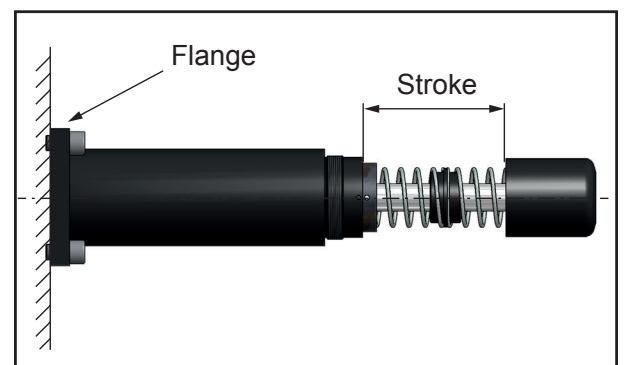

Safety Instructions

Before installation, commissioning, servicing and repair the data sheet is to be noticed. This work may only be performed by trained, introduced staff.

Electric connections according to the suitable national regulation. For Germany: VDE regulation VD E0100

Before all repair and servicing works the energy supplies (main switch, etc.) have to be switched off! Moreover, measures are necessary to prevent an unintentional reconnect. For example, a warning sign "service works" or "maintenance work", applied to the switch.

Designated use

Check before installation and make sure the type name on the shock absorber or on the packaging is corresponding with delivery note. Industrial shock absorbers are maintenance-free and ready for installation.

- Temperature influence: at higher temperatures the shock absorber characteristic will change.
- Movable loads have to be protected during the installation and maintenance against unintentional processes.
- In operation outside the allowed temperature range, the shock absorber can lose his function. Due to heat radiation don't paint the shock absorber.
- Fluids, gases and a dirty environment can affect or destroy the sealing system of the shock absorber. The result could be a failure malfunction. Piston rod and sealing system has to be protected against fluids, gases and a dirty environment.
- Damages at the piston rod can destroy the sealing system. Don't grease or oil the piston rod.
- Avoid traction forces on the piston rod to present internal damages.
- The shock absorber can be pulled out of the construction during the impact. The construction needs to be able to resist the max counterforce. Sufficient security must be calculated.
The maximum counterforces performed in the calculation program can vary from the really appearing counter forces, because these are based on theoretical values.

Fundamentals

Shock absorbers may under no circumstances be:

-painted



-welded



-held with clamps



-used on pull*



(exception: clevis mounting)

In hazardous environments (dirt, humidity, oil) shock absorbers must be protected against damage and failure with the necessary accessory. If several shock absorbers are used on the same application, the deceleration has to be distributed equally. The "Torque" (PERFORMANCE) indicates the maximum force by using the flats. The Weforma catalogue shows technical data with both minimum and maximum values. If a product is to be used in continuous operation and within a range of 20% from the minimum and maximum values shown, then written confirmation of suitability of use from Weforma is necessary.

Important information

Integrated end-stop

Up to the Mega-Line series 4,0 the shock absorbers are provided with an integrated end-stop. If the integrated end-stop is used the remaining energy before end of stroke must not be higher than 10% of the total energy. For all models which are used as an emergency stop an external fixed stop is necessary.



Installation situation

The installation situation is any, however always in such a way that the complete shock absorber stroke can be used. The shock absorbers must be mounted like that the forces in centerline about the piston rod are initiated. The maximum angle out of centre amounts to 2 °.

Liability

Due to the number of possible uses of our products and the conditions of use that lie outside of our scope of influence, we accept no liability as to whether the purchase object is suitable for the Client's intended purpose. The verification to this effect, in particular the verification as to whether the purchase object is suitable for the planned use, is the responsibility of the Client alone, unless expressly agreed otherwise in writing.

For the reasons we accept no liability for the suitability of the purchase object for the purpose intended by the Client, except in cases of intent or gross negligence.

With damages, the not designated use and from high-handed, in these instructions do not originate to intended interventions, any guarantee and liability claim goes out towards the manufacturer.

Guarantee

By non-use of the original spare parts the guarantee claim goes out.

Environment protection

By the exchange from damaged parts is to be respected to a proper disposal.