

Shock Absorbers

Mega-Line WS-M / WP-M 1,0

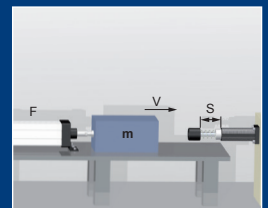

ONLINE
Calculation +
2D / 3D CAD Download



Benefits

Enlarged piston:

- Max. +400% energy
- Max. -50% costs / Nm



Piston:

- Hardened, aluminium-titanium-nitride coated

Integrated stop:

- Max. security

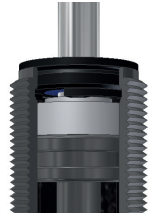

ProSurf:

- Surface protection against corrosion



Flats :

- Fast mounting

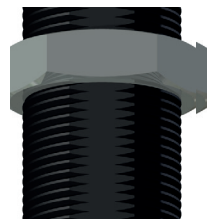

Special models:

- Stainless steel:
V4A/DIN1.4404/AISL 316L
- For pressure chambers up to 7 bar
- USDA-H 1 compliant for food industry
- Cleanroom

Temperature:

- Standard: -20°C - ...+80°
- Low-temperature: -50°C-...+60°C
- High-temperature: 0°C-...+120°C

Stop caps:

A:

- Standard from POM
- Increased protection of the impact surface

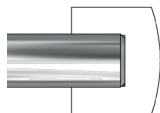

AP:

- 40% noise reduction due to PU
- Increased protection of the impact surface

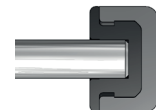

AP2:

- Longer life time compared to stop cap AP and plastic cap A

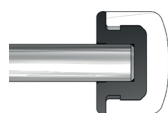

AS:

- From hardened steel
- For side forces and difficult operating conditions



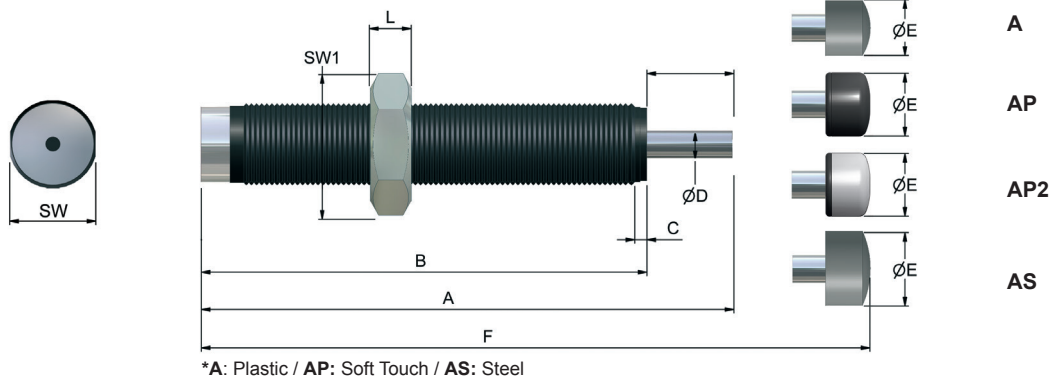

DIMENSIONS

	GW*	A	B	C	øD	øE (A)	øE (AP / AP2)	øE (AS)	F (A)	F (AP / AP2)	F (AS)	K	L	SW	SW1	SW2	F (B)	øM	H
		mm	mm	mm	mm	mm	mm	mm	mm	mm	mm	mm	mm	mm	mm	mm	mm	mm	mm
WS-M 1,0	M 24 x 1,5	133	108	3,5	8	16	21	20	146	148	146	-	8	23	30	-	146	30	50
WP-M 1,0	M 24 x 1,5	133	108	3,5	8	16	21	20	146	148	146	-	8	23	30	-	146	30	50
WS-M 1,0 x 40	M 24 x 1,5	170	130	3,5	8	16	21	20	183	185	183	-	8	23	30	-	-	-	-
WP-M 1,0 x 40	M 24 x 1,5	170	130	3,5	8	16	21	20	183	185	183	-	8	23	30	-	-	-	-
WS-M 1,0 x 80	M 24 x 1,5	313	233	3,5	8	16	21	20	326	328	326	-	8	-	30	-	-	-	-
WP-M 1,0 x 80	M 24 x 1,5	313	233	3,5	8	16	21	20	326	328	326	-	8	-	30	-	-	-	-

SPECIAL THREAD - from stock

Series	Code	Threads	Example
1,0	T	M 25x1,5	WS-M 1,0-1T
1,0	R	M 27x3	WP-M 1,0-1R
1,0	U	1 - 12 UNF	WS-M 1,0-1U
1,0	M	M 24x1,25	WP-M 1,0-1M
1,0	H	M 25x2	WS-M 1,0-1H
1,0	K	M 26x1,5	WP-M 1,0-1K
1,0	G	M 27x1,5	WS-M 1,0-1G
1,0 x 40	T	M25x1,5	WS-M 1,0 x 40-1T
1,0 x 40	R	M27x3	WP-M 1,0 x 40-1R
1,0 x 40	U	1-12 UNF	WS-M 1,0 x 40-1U
1,0 x 40	D	M27x2	WP-M 1,0 x 40-1M
1,0 x 40	L	M30x1,5	WS-M 1,0 x 40-1L
1,0 x 80	T	M25x1,5	WS-M 1,0 x 80-1T

STAINLESS STEEL - from stock

Series	Code	Threads	Example
1,0		M 24x1,5	WS-M 1,0-1-VA
1,0	T	M 25x1,5	WP-M 1,0-1T-VA
1,0	R	M 27x3	WS-M 1,0-1R-VA
1,0	U	1 - 12 UNF	WP-M 1,0-1U-VA
1,0 x 40		M 24x1,5	WS-M 1,0 x 40-1-VA
1,0 x 40	T	M 25x1,5	WP-M 1,0 x 40-1T-VA
1,0 x 40	R	M 27x3	WS-M 1,0 x 40-1R-VA
1,0 x 40	L	M 30x1,5	WP-M 1,0 x 40-1L-VA

PERFORMANCE

	Stroke	Energy absorption		Effective mass				
		Constant load*	Nm/h (max.)	-0 (very soft)	-1 (soft)	-2 (medium)	-3 (hard)	-4 (very hard)
		Nm/HB (max.)		min. - max.kg	min. - max.kg	min. - max.kg	min. - max.kg	min. - max.kg
WS-M 1,0	25	220	105.600	6 - 29	24 - 120	70 - 460	440 - 2.050	1760 - 10.800
WP-M 1,0	25	220	105.600	-	6 - 27,5	21 - 195	150 - 1200	-
WS-M 1,0 x 40	40	390	175.500	15 - 103	44 - 216	135 - 962	780 - 3.600	3100 - 19.500
WP-M 1,0 x 40	40	390	175.500	-	10 - 48	39 - 340	270 - 2150	-
WS-M 1,0 x 80	80	390	175.500	15 - 103	44 - 216	135 - 962	780 - 3.600	3100 - 19.500
WP-M 1,0 x 80	80	390	175.500	-	10 - 48	39 - 340	270 - 2150	-

Technical data at + 20°C

Technical Data

Weight	1,0:	0,29 kg
	1,0 x 40:	0,39 kg
	1,0 x 80:	0,63 kg
Impact speed	WS-M:	0,08 - 6,0 m/s
	WP-M:	0,30 - 8,0 m/s
Return spring force	1,0:	15 N/min - 31 N/max
	Ausführung „BO“:	60 N/min - 80 N/max
	1,0 x 40:	11 N/min - 20 N/max
	1,0 x 80:	14 N/min - 31 N/max
Torque: max. force by using the flats	1,0 / 1,0 x 40 / 1,0 x 80:	30 Nm
Housing		ProSurf
Piston rod		Hardened stainless steel
RoHS - compliant		Directive 2002/95/EG
Included		1 lock nut

Accessories

Stop limit nut

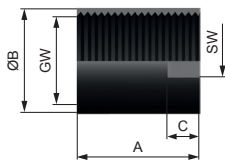

GW*	A mm	ØB mm	C mm	SW mm	Art.-Nr.
M24x1,5	38	31	10	30	21238
M26x1,5	38	34	10	30	21238K
M27x1,5	38	34	10	30	21238G
M27x3	38	34	10	30	21238R
Stainless steel					
M24x1,5	38	31	10	30	21238VA

Rectangular flange

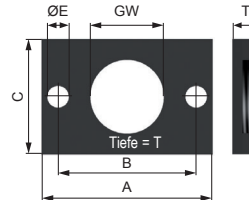

GW*	A mm	B mm	C mm	E mm	T mm	Art.-Nr.
M24x1,5	52	42	35	6,6	8	SK21233
M25x1,5	52	42	35	6,6	8	SK21233T
M27x3	52	42	35	6,6	8	SK21233R

Clamping flange

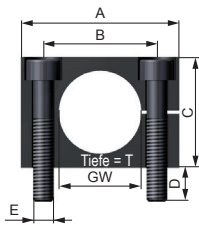

GW*	A mm	B mm	C mm	D mm	E mm	T mm	Art.-Nr.
M24x1,5	46	33	32	6	M6	25	S21233
M25x1,5	47	34	32	6	M6	25	S21233T
M27x3	46	33	32	6	M6	25	S21233R

Lock nut

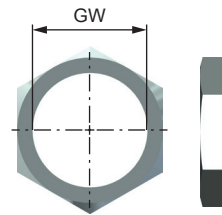

GW*	Art.-Nr.
M24x1,5	21232
M25x1,5	21232T
M25x2	21232H
M26x1,5	21232K
M27x1,5	21232G
M27x3	21232R
1-12UNF	21232U
Stainless steel	
M24x1,5	21232VA

Proximity Switch

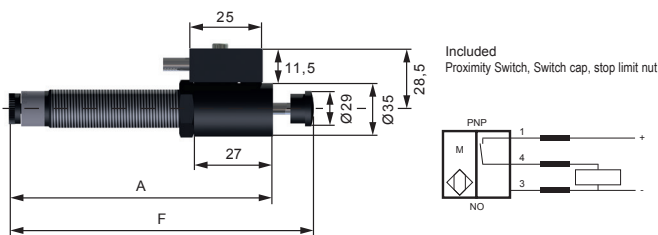

	A (mm)	F (mm)	Art.-Nr.
WS-M 1,0	114,5	146	S21264
WP-M 1,0	114,5	146	S41264
WS-M 1,0x40	136,5	183	S21264
WP-M 1,0x40	136,5	183	S41264

	A (mm)	F (mm)	Art.-Nr.
WS-M 1,0x80	239,5	326	S21264
WP-M 1,0x80	239,5	326	S41264

Double wiper

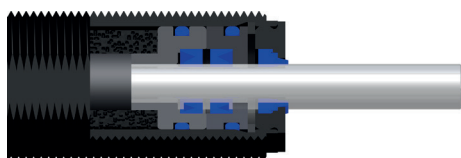

Used in applications with:

- Liquid
- Compressed air
- Dust

Accessories

Clevis mounting

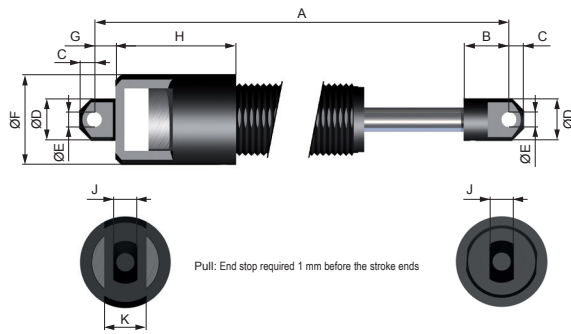

Code: S21216

	A mm	B mm	C mm	ØD mm	ØE mm	ØF mm	G mm	H mm	J mm	K mm
WS-M 1,0SB	158	15	5	14	5	30	7	40	8	14
WP-M 1,0SB										

Shock Absorbers with protection bellow

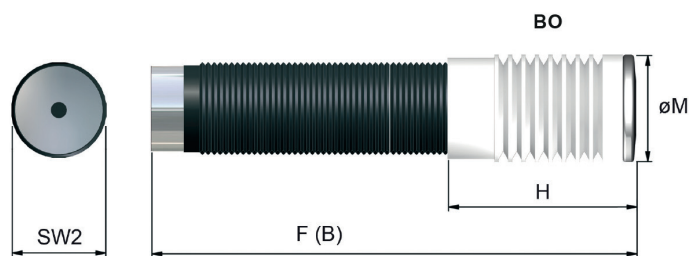

Material: PTFE / stop cap: stainless steel
 Ordering information: -M 1,0 - BO

Solutions for Side Forces

1) AK 1

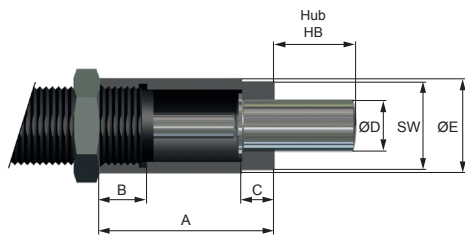

	GW*	A mm	B mm	C mm	Ø D mm	Ø E mm	SW mm	Art.-Nr.
1,0	M24x1,5	53,5	14,5	10	16	29	27	S21219
1,0	M25x1,5	53,5	14,5	10	16	29	27	S21219T

AK 2

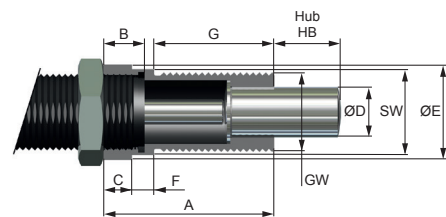

	GW*	A mm	B mm	C mm	Ø D mm	Ø E mm	F mm	G mm	SW mm	Art.-Nr.
1,0	M24x1,5	54	13	9	16	30	7	38	27	S21219-AK2
1,0	M25x1,5	54	13	9	16	30	7	38	27	S21219T-AK2

2) WSB-M / WPB-M 1,0

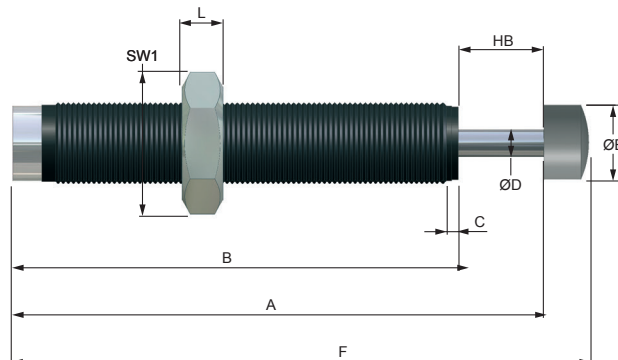

BENEFITS

Designed for side forces up to 15° without additional mounting parts;
included steel stop cap

DIMENSIONS

		GW*	A	A 1	B	C	Ø D	Ø E	L	SW	SW 1
			mm	mm	mm	mm	mm	mm	mm	mm	mm
WSB-M 1,0-0/1/2/3/4	WPB-M 1,0-1/2/3	M 24 x 1,5	146,0	154,0	108,0	3,5	8	20	8	23	30
WSB-M 1,0T-0/1/2/3/4	WPB-M 1,0T-1/2/3	M 25 x 1,5	146,0	154,0	108,0	3,5	8	20	8	23	30
WSB-M 1,0R-0/1/2/3/4	WPB-M 1,0R-1/2/3	M 27 x 3	146,0	154,0	108,0	3,5	8	20	8	23	30

PERFORMANCE

	Stroke	Energy absorption		Effective mass					Return spring force		Torque	Weight
				-0 (very soft)	-1 (soft)	-2 (medium)	-3 (hard)	-4 (very hard)	min. N	max. N		
	mm	Nm/HB (max.)	Nm/h (max.)	min.-max.kg	min.-max.kg	min.-max.kg	min.-max.kg	min.-max.kg	min. N	max. N	Nm max.	kg
WSB-M 1,0	25	180	108000	6 - 29	24 - 120	70 - 460	440 - 2050	1760 - 10800	15	31	30	0,25
WPB-M 1,0	25	180	108000	-	6 - 27,5	21 - 195	150 - 1200	-	15	31	30	0,25

Adjustment

The shock absorbers Mega-Line 1,0 are self-adjusting.

Damping characteristics:

WS-M - self-adjusting, linear

WP-M - self-adjusting, progressively

The attenuation factor are available by default:

- 0 - very soft
- 1 - soft
- 2 - medium
- 3 - hard
- 4 - very hard

The damping level is calculated with the formula for the effective mass. (see calculation in the catalog)

If the mass in a trial run impacts excessively hard on the fixed stop select the next harder model. If the mass impacts too hard on the shock absorber choose a softer version.

Installation

Installation with Lock nut

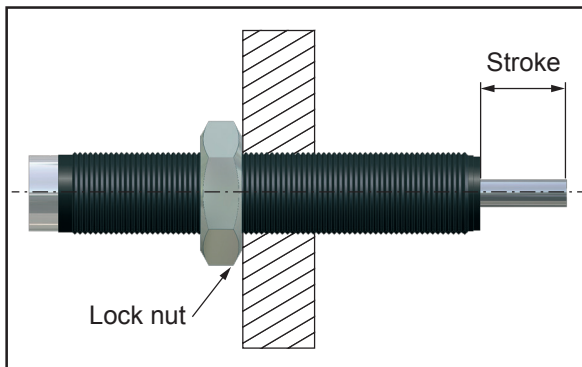

Installation with flange

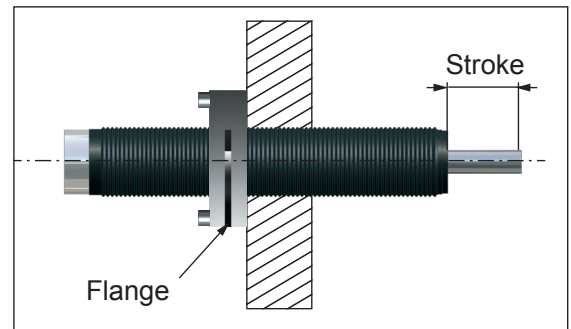

Installation with stop limit nut

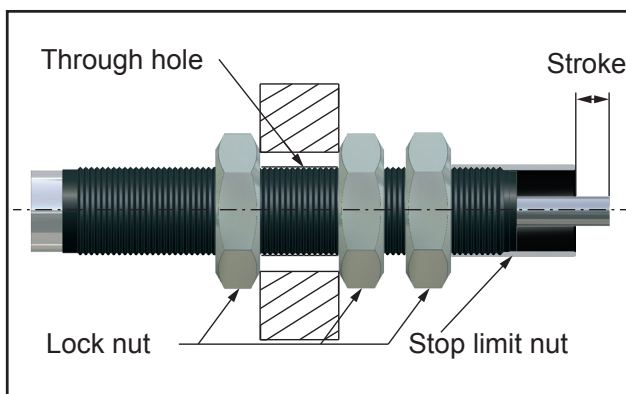

Clevis mounting

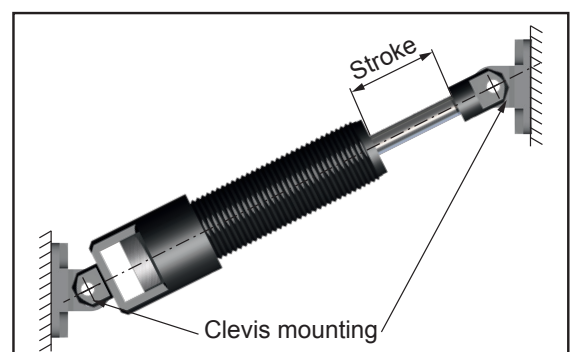

Safety Instructions

Before installation, commissioning, servicing and repair the data sheet is to be noticed. This work may only be performed by trained, introduced staff.

Electric connections according to the suitable national regulation. For Germany: VDE regulation VD E0100

Before all repair and servicing works the energy supplies (main switch, etc.) have to be switched off! Moreover, measures are necessary to prevent an unintentional reconnect. For example, a warning sign "service works" or "maintenance work", applied to the switch.

Designated use

Check before installation and make sure the type name on the shock absorber or on the packaging is corresponding with delivery note. Industrial shock absorbers are maintenance-free and ready for installation.

- Temperature influence: at higher temperatures the shock absorber characteristic will change.
- Movable loads have to be protected during the installation and maintenance against unintentional processes.
- In operation outside the allowed temperature range, the shock absorber can lose his function. Due to heat radiation don't paint the shock absorber.
- Fluids, gases and a dirty environment can affect or destroy the sealing system of the shock absorber. The result could be a failure malfunction. Piston rod and sealing system has to be protected against fluids, gases and a dirty environment.
- Damages at the piston rod can destroy the sealing system. Don't grease or oil the piston rod.
- Avoid traction forces on the piston rod to present internal damages.
- The shock absorber can be pulled out of the construction during the impact. The construction needs to be able to resist the max counterforce. Sufficient security must be calculated.
The maximum counterforces performed in the calculation program can vary from the really appearing counter forces, because these are based on theoretical values.

Fundamentals

Shock absorbers may under no circumstances be:

-painted



-welded



-held with clamps



-used on pull*



(exception: clevis mounting)

In hazardous environments (dirt, humidity, oil) shock absorbers must be protected against damage and failure with the necessary accessory. If several shock absorbers are used on the same application, the deceleration has to be distributed equally. The "Torque" (PERFORMANCE) indicates the maximum force by using the flats. The Weforma catalogue shows technical data with both minimum and maximum values. If a product is to be used in continuous operation and within a range of 20% from the minimum and maximum values shown, then written confirmation of suitability of use from Weforma is necessary.

Important information

Integrated end-stop

Up to the WS-M and WP-M 1,0 Mega-Line series the shock absorbers are provided with an integrated end-stop. If the integrated end-stop is used the remaining energy before end of stroke must not be higher than 10% of the total energy. For all models which are used as an emergency stop an external fixed stop is necessary.

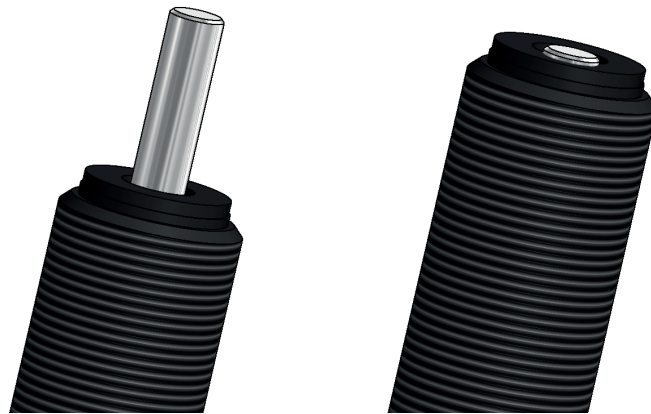

Installation situation

The installation situation is any, however always in such a way that the complete shock absorber stroke can be used. The shock absorbers must be mounted like that the forces in centerline about the piston rod are initiated. The maximum angle out of centre amounts to 2°. With a bigger angle out of centre an AK1 / AK2 (see 'solutions for side forces') must be used or the shock absorber serie: WSB/WPB

Liability

Due to the number of possible uses of our products and the conditions of use that lie outside of our scope of influence, we accept no liability as to whether the purchase object is suitable for the Client's intended purpose. The verification to this effect, in particular the verification as to whether the purchase object is suitable for the planned use, is the responsibility of the Client alone, unless expressly agreed otherwise in writing.

For the reasons we accept no liability for the suitability of the purchase object for the purpose intended by the Client, except in cases of intent or gross negligence.

With damages, the not designated use and from high-handed, in these instructions do not originate to intended interventions, any guarantee and liability claim goes out towards the manufacturer.

Guarantee

By non-use of the original spare parts the guarantee claim goes out.

Environment protection

By the exchange from damaged parts is to be respected to a proper disposal.