

Shock Absorbers

Mega-Line WS-M / WP-M 1,25

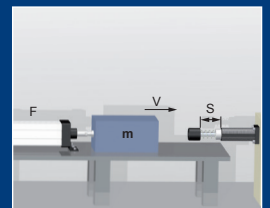

ONLINE
Calculation +
2D / 3D CAD Download



Benefits

Helix-Principle:

- Max. +300% Energy
- Max. -50% Costs / Nm

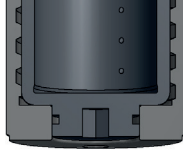

Pro Adjust:

- Protected adjustment



ProTec:

- Solid body without retaining ring

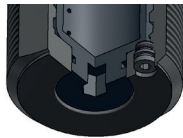

Piston:

- Hardened, Aluminium-Titanium-Nitride coated
- Special seals + oils

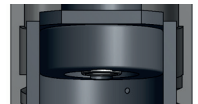

Extended life cycle:

- Nitrated guidance system

Integrated end stop:

- Max. security

Models:

- Black finish

Temperature:

Standard: -20°C-...+80°C

Low temperature: -50°C-...+60°C

High temperature: 0°C-...+120°C

Special edition :

- ProSurf
- V4A(/DIN1.440/AISL 316L)
- For pressure chambers up to 7 bar
- USDA-H 1 compliant for food industry
- Cleanroom

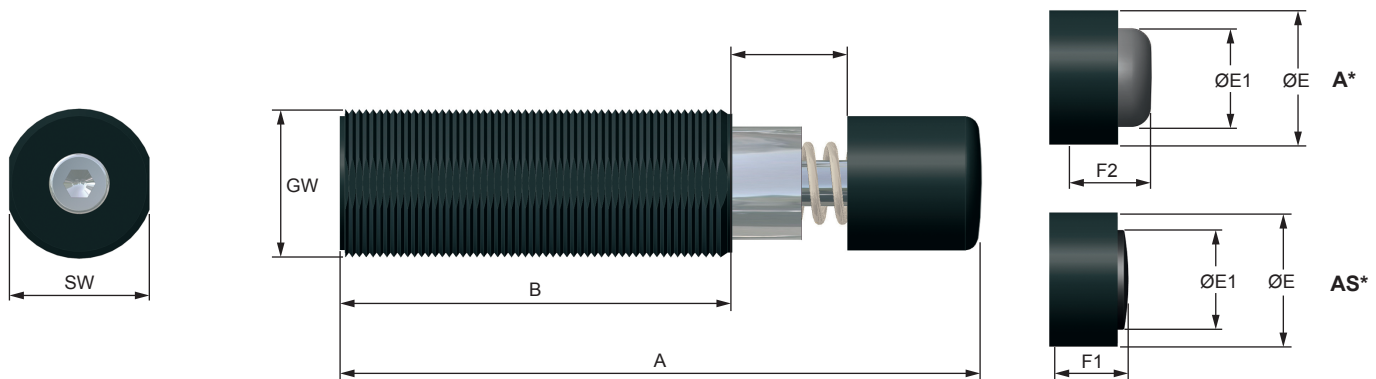

*A: PU / AS: Steel
Add "A / AS" after the part no.

DIMENSIONS

	GW*	A	B	ø E	ø E1	F1	F2	SW
		mm	mm	mm	mm	mm	mm	mm
WS-M 1,25 x 1	M 32 x 1,5	138	85	29	21	12	16	30
WP-M 1,25 x 1	M 32 x 1,5	138	85	29	21	12	16	30
WS-M 1,25 x 2	M 32 x 1,5	188	110	29	21	12	16	30
WP-M 1,25 x 2	M 32 x 1,5	188	110	29	21	12	16	30
WS-M 1,25 x 3	M 32 x 1,5	243	140	29	21	12	16	30
WP-M 1,25 x 3	M 32 x 1,5	243	140	29	21	12	16	30
WS-M 1,25 x 4	M 32 x 1,5	306	154	29	21	12	16	30
WP-M 1,25 x 4	M 32 x 1,5	306	154	29	21	12	16	30

SPECIAL THREAD - from stock

Series	Code	Threads	Example
1,25	D	M 30x2	WS-M 1,25x1-1D
1,25	H	M 33x1,5	WP-M 1,25x1-1H
1,25	L	M 36x1,5	WS-M 1,25x1-1L
1,25	F	M 37x1,5	WP-M 1,25x1-1F
1,25	R	M 42x3	WS-M 1,25x1-1R
1,25	U	1 1/4-12 UNF	WP-M 1,25x1-1U
1,25	UF	1 3/8-12 UNF	WS-M 1,25x1-1UF

STAINLESS STEEL - from stock

Series	Code	Threads	Example
1,25 x 1		M 32x1,5	WS-M 1,25x1-1VA
1,25 x 2		M 32x1,5	WP-M 1,25x2-1VA
1,25 x 1	H	M 33x1,5	WS-M 1,25x1-1H-VA
1,25 x 2	H	M 33x1,5	WP-M 1,25x2-1H-VA
1,25 x 1	U	1 1/4-12 UNF	WS-M 1,25x1-1U-VA
1,25 x 2	U	1 1/4-12 UNF	WP-M 1,25x2-1U-VA
1,25 x 1	L	M 36x1,5	WS-M 1,25x1-1L-VA
1,25 x 2	L	M 36x1,5	WP-M 1,25x2-1L-VA

PERFORMANCE

	Stroke	Energy absorption			Effective mass				
		Constant load*		External tank**	-0 (very soft)	-1 (soft)	-2 (medium)	-3 (hard)	-4 (very hard)
		Nm/HB (max.)	Nm/h (max.)	Nm/h	min. - max.kg	min. - max.kg	min. - max.kg	min. - max.kg	min. - max.kg
WS-M 1,25 x 1	25	300	120.000	240.000	7 - 32	28 - 130	80 - 590	440 - 2.050	2.000 - 12.500
WP-M 1,25 x 1	25	300	120.000	240.000	-	7 - 35	30 - 260	207 - 1.650	-
WS-M 1,25 x 2	50	500	150.000	300.000	13 - 60	56 - 240	160 - 1.200	1.000 - 4.200	4.000 - 25.000
WP-M 1,25 x 2	50	500	150.000	300.000	-	7 - 35	30 - 260	207 - 1.650	-
WS-M 1,25 x 3	75	750	225.000	450.000	20 - 99	85 - 400	240 - 1.850	1.000 - 7.000	6.000 - 37.000
WP-M 1,25 x 3	75	750	225.000	450.000	-	20 - 99	75 - 660	520 - 4.100	-
WS-M 1,25 x 4	100	900	270.000	540.000	25 - 112	100 - 500	290 - 2.220	1.800 - 8.500	7.200 - 45.000
WP-M 1,25 x 4	100	900	270.000	540.000	-	25 - 112	88 - 800	622 - 5.000	-

Technical data at + 20°C

Technical Data

Weight	1,25 x 1:	0,45 kg
	1,25 x 2:	0,55 kg
	1,25 x 3:	0,70 kg
	1,25 x 4:	0,85 kg
Impact speed	WS-M:	0,10 - 6,0 m/s
	WP-M:	0,40 - 8,0 m/s
Return spring force	1,25 x 1 :	30 N/min - 50 N/max
	1,25 x 2 / 1,25 x 4 :	23 N/min - 50 N/max
	1,25 x 3 :	15 N/min - 100 N/max
Torque:	1,25 :	40 Nm
Max. force by using the flats		
Housing		Black finish
Piston rod		Hardened stainless steel
RoHS - compliant		Directive 2002/95/EG

Accessories

Lock nut

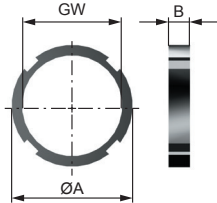

Code.: S23012

GW	ØA mm	B mm	Art.-Nr.
M32x1,5	38	6,5	S23012
M33x1,5	38	6,5	S23012H
M36x1,5	41	6,5	S23012L
M42x3	54	8	S23012R
11/4-12 UNF	41	6,5	S23012U
12/8-12 UNF	41	6,5	S23012UF
Edelstahl			
M32x1,5	38	6,5	S23012VA
M33x1,5	38	6,5	S23012H-VA
M36x1,5	41	6,5	S23012L-VA

Stop limit nut

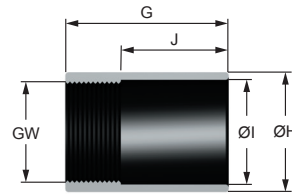

Code.: S23018

GW	ØI mm	ØH mm	G mm	J mm	Art.-Nr.
M32x1,5	33	38	60	35	S23018
M33x1,5	34	38	60	35	S23018H
M36x1,5	36,5	44	60	35	S23018L
1 1/4-12UNF	33	38	60	35	S23018U

Square flange

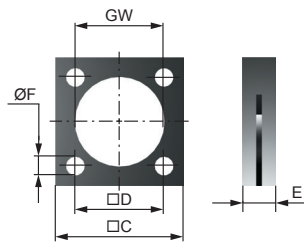

Code.: S23014

GW	ØF mm	E mm	D mm	C mm	Art.-Nr.
M32x1,5	6,6	12	31	45	S23014
M33x1,5	6,6	12	32	45	S23014H
M36x1,5	6,6	12	32	45	S23014L
11/4-12 UNF	6,6	12	32	45	S23014U

Foot mounting

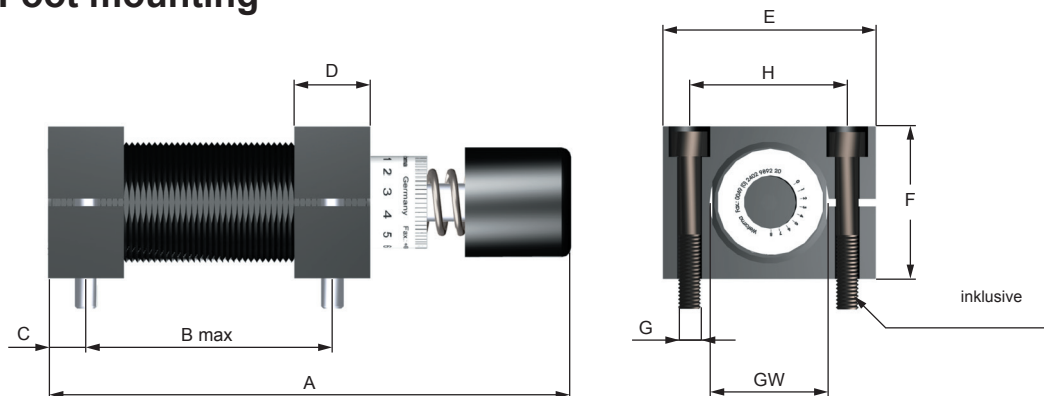

	GW*	A	B max	C	D	E	F	G	H	Code
		mm	mm	mm	mm	mm	mm	mm	mm	
1,25 x 1	M 32 x 1,5	138	65	10	20	56	40	M6	41	S23015
1,25 x 2	M 32 x 1,5	188	90	10	20	56	40	M6	41	S23015
1,25 x 3	M 32 x 1,5	243	120	10	20	56	40	M6	41	S23015
1,25 x 1U	1 1/4-12UNF	138	65	10	20	56	40	M6	42	S23015U
1,25 x 2U	1 1/4-12UNF	188	90	10	20	56	40	M6	42	S23015U
1,25 x 3U	1 1/4-12UNF	243	120	10	20	56	40	M6	42	S23015U
1,25 x 1L	M 36 x 1,5	138	65	10	20	56	40	M6	43	S23015L
1,25 x 2L	M 36 x 1,5	188	90	10	20	56	40	M6	43	S23015L
1,25 x 3L	M 36 x 1,5	243	120	10	20	56	40	M6	43	S23015L
1,25 x 1H	M 33 x 1,5	138	65	10	20	56	40	M6	42	S23015H
1,25 x 2H	M 33 x 1,5	188	90	10	20	56	40	M6	42	S23015H
1,25 x 3H	M 33 x 1,5	243	120	10	20	56	40	M6	42	S23015H

Accessories

Clevis mounting

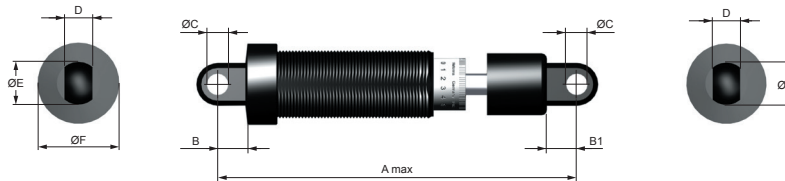

Pull: End stop required 1 mm before the stroke ends

Standard: Shock absorber with clevis mounting is delivered without return spring.
Return spring is available on request.

Code.: S23016

	GW*	A max	B	B1	ø C	D	ø E	ø F	G	H	I	J	ø K	L	M	N	ø O	P
		mm	mm	mm	mm	mm	mm	mm	mm	mm	mm	mm	mm	mm	mm	mm	mm	mm
1,25 x 1	M32x1,5	168	14	14	10	13	20	38	45	32	14	34	6,5	22	13	5	10	20
1,25 x 2	M32x1,5	218	14	14	10	13	20	38	45	32	14	34	6,5	22	13	5	10	20
1,25 x 3	M32x1,5	273	14	14	10	13	20	38	45	32	14	34	6,5	22	13	5	10	20
1,25 x 1H	M33x1,5	168	14	14	10	13	20	38	45	32	14	34	6,5	22	13	5	10	20
1,25 x 2H	M33x1,5	218	14	14	10	13	20	38	45	32	14	34	6,5	22	13	5	10	20
1,25 x 3H	M33x1,5	273	14	14	10	13	20	38	45	32	14	34	6,5	22	13	5	10	20
1,25 x 1L	M36x1,5	168	14	14	10	13	20	38	45	32	14	34	6,5	22	13	5	10	20
1,25 x 2L	M36x1,5	218	14	14	10	13	20	38	45	32	14	34	6,5	22	13	5	10	20
1,25 x 3L	M36x1,5	273	14	14	10	13	20	38	45	32	14	34	6,5	22	13	5	10	20
1,25 x 1U	1 1/4-12UNF	168	14	14	10	13	20	38	45	32	14	34	6,5	22	13	5	10	20
1,25 x 2U	1 1/4-12UNF	218	14	14	10	13	20	38	45	32	14	34	6,5	22	13	5	10	20
1,25 x 3U	1 1/4-12UNF	273	14	14	10	13	20	38	45	32	14	34	6,5	22	13	5	10	20

AK 1

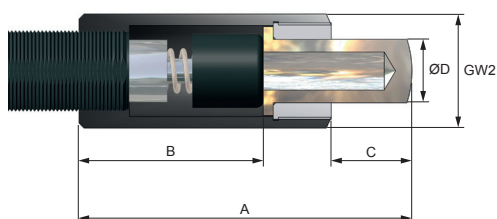

	GW1	GW2	A	B	C	ø D	Code
			mm	mm	mm	mm	
1,25 x 1	M32x1,5	M45x2	132,0	73	32,0	25	S23019
1,25 x 2	M32x1,5	M45x2	184,5	98	59,5	25	S23119
1,25 x 1H	M33x1,5	M45x2	132,0	73	32,0	25	S23019H
1,25 x 2H	M33x1,5	M45x2	184,5	98	59,5	25	S23119H

Accessories

Protection bellow

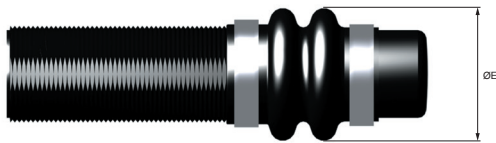

	Ø E mm	Code
1,25 x 1	65	S23017
1,25 x 2	65	S23117

External Tanks

AT 1

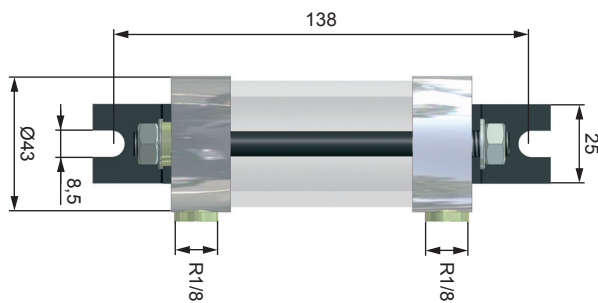

Code.: 23810

WS-M 1,25
WP-M 1,25

WS-M 1,25 x 2 - 1AT
For shock absorbers without return spring

WS-M 1,25 x 2 - 1 ATF
For shock absorbers with return spring

WM-AT 1
For external Tanks

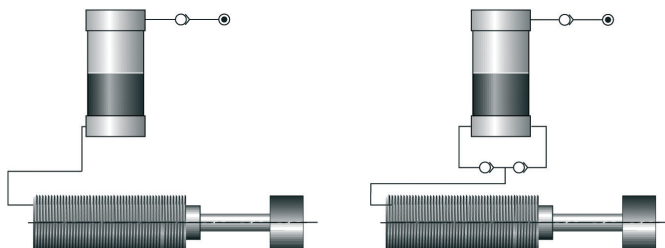

Benefits:

Optimum cooling and therefore higher energy absorption per hour“

Adjustment

The shock absorbers Mega-Line 1,25 are self-adjusting.

Damping characteristics:

WS-M - self-adjusting, linear

WP-M - self-adjusting, progressively

The attenuation factor are available by default:

- 0 - very soft
- 1 - soft
- 2 - medium
- 3 - hard
- 4 - very hard

The damping level is calculated with the formula for the effective mass. (see calculation in the catalog)

If the mass in a trial run impacts excessively hard on the fixed stop select the next harder model. If the mass impacts too hard on the shock absorber choose a softer version.

Installation

Foot mounting

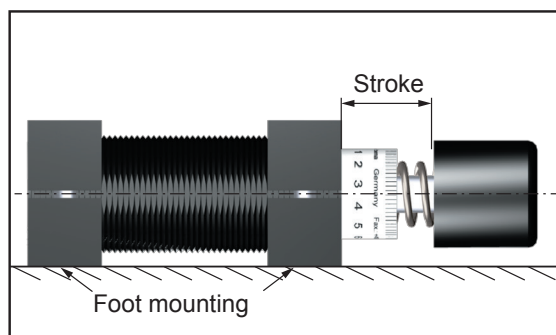

Clevis mounting

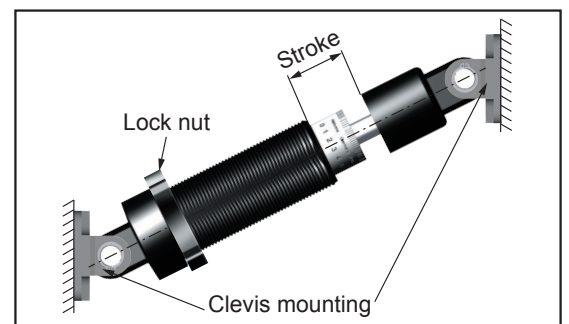

Installation with stop limit nut

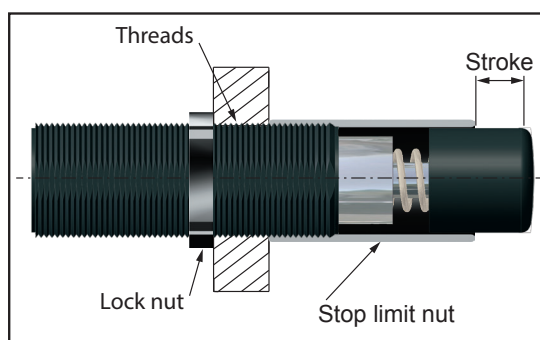

Installation with flange

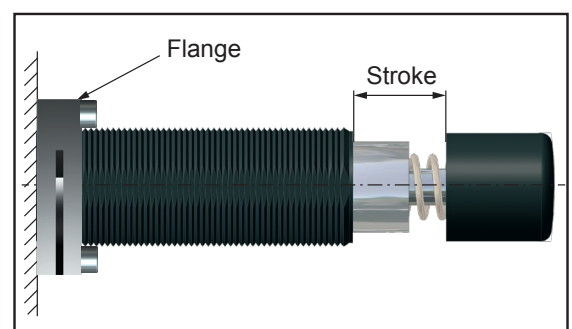

Safety Instructions

Before installation, commissioning, servicing and repair the data sheet is to be noticed. This work may only be performed by trained, introduced staff.

Electric connections according to the suitable national regulation. For Germany: VDE regulation VD E0100

Before all repair and servicing works the energy supplies (main switch, etc.) have to be switched off! Moreover, measures are necessary to prevent an unintentional reconnect. For example, a warning sign "service works" or "maintenance work", applied to the switch.

Designated use

Check before installation and make sure the type name on the shock absorber or on the packaging is corresponding with delivery note. Industrial shock absorbers are maintenance-free and ready for installation.

- Temperature influence: at higher temperatures the shock absorber characteristic will change.
- Movable loads have to be protected during the installation and maintenance against unintentional processes.
- In operation outside the allowed temperature range, the shock absorber can lose his function. Due to heat radiation don't paint the shock absorber.
- Fluids, gases and a dirty environment can affect or destroy the sealing system of the shock absorber. The result could be a failure malfunction. Piston rod and sealing system has to be protected against fluids, gases and a dirty environment.
- Damages at the piston rod can destroy the sealing system. Don't grease or oil the piston rod.
- Avoid traction forces on the piston rod to present internal damages.
- The shock absorber can be pulled out of the construction during the impact. The construction needs to be able to resist the max counterforce. Sufficient security must be calculated.
The maximum counterforces performed in the calculation program can vary from the really appearing counter forces, because these are based on theoretical values.

Fundamentals

Shock absorbers may under no circumstances be:

-painted



-welded



-held with clamps



-used on pull*



(exception: clevis mounting)

In hazardous environments (dirt, humidity, oil) shock absorbers must be protected against damage and failure with the necessary accessory. If several shock absorbers are used on the same application, the deceleration has to be distributed equally. The "Torque" (PERFORMANCE) indicates the maximum force by using the flats. The Weforma catalogue shows technical data with both minimum and maximum values. If a product is to be used in continuous operation and within a range of 20% from the minimum and maximum values shown, then written confirmation of suitability of use from Weforma is necessary.

Important information

Integrated end-stop

Up to the Mega-Line series 1,25 the shock absorbers are provided with an integrated end-stop. If the integrated end-stop is used the remaining energy before end of stroke must not be higher than 10% of the total energy. For all models which are used as an emergency stop an external fixed stop is necessary.

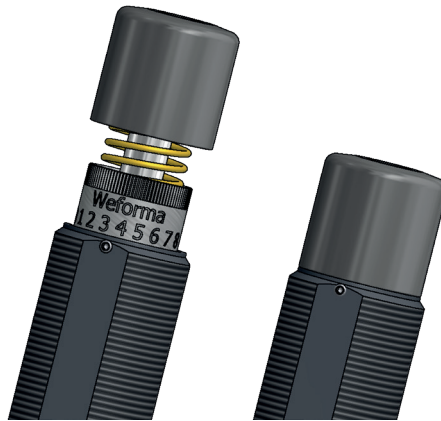

Installation situation

The installation situation is any, however always in such a way that the complete shock absorber stroke can be used. The shock absorbers must be mounted like that the forces in centerline about the piston rod are initiated. The maximum angle out of centre amounts to 2 °.

Liability

Due to the number of possible uses of our products and the conditions of use that lie outside of our scope of influence, we accept no liability as to whether the purchase object is suitable for the Client's intended purpose. The verification to this effect, in particular the verification as to whether the purchase object is suitable for the planned use, is the responsibility of the Client alone, unless expressly agreed otherwise in writing.

For the reasons we accept no liability for the suitability of the purchase object for the purpose intended by the Client, except in cases of intent or gross negligence.

With damages, the not designated use and from high-handed, in these instructions do not originate to intended interventions, any guarantee and liability claim goes out towards the manufacturer.

Guarantee

By non-use of the original spare parts the guarantee claim goes out.

Environment protection

By the exchange from damaged parts is to be respected to a proper disposal.