

## Shock Absorbers

Mega-Line WS-M / WP-M 2,0

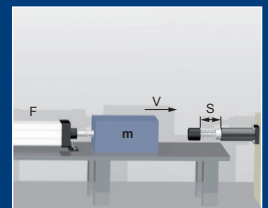

**ONLINE**  
Calculation +  
2D / 3D CAD Download



## Benefits

### Helix-Principle:

- Max. +300% Energy
- Max. -50% Costs / Nm

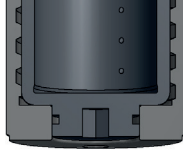

### Pro Adjust:

- Protected adjustment



### ProTec:

- Solid body without retaining ring

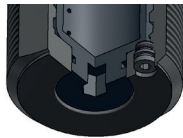

### Piston:

- Hardened, Aluminium-Titanium-Nitride coated
- Special seals + oils

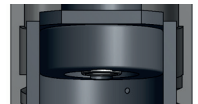

### Extended life cycle:

- Nitrated guidance system

### Integrated end stop:

- Max. security

### Models:

- Black finish

### Temperature:

Standard: -20°C-...+80°C

Low temperature: -50°C-...+60°C

High temperature: 0°C-...+120°C

### Special edition :

- ProSurf
- V4A(/DIN1.440/AISL 316L)
- For pressure chambers up to 7 bar
- USDA-H 1 compliant for food industry
- Cleanroom

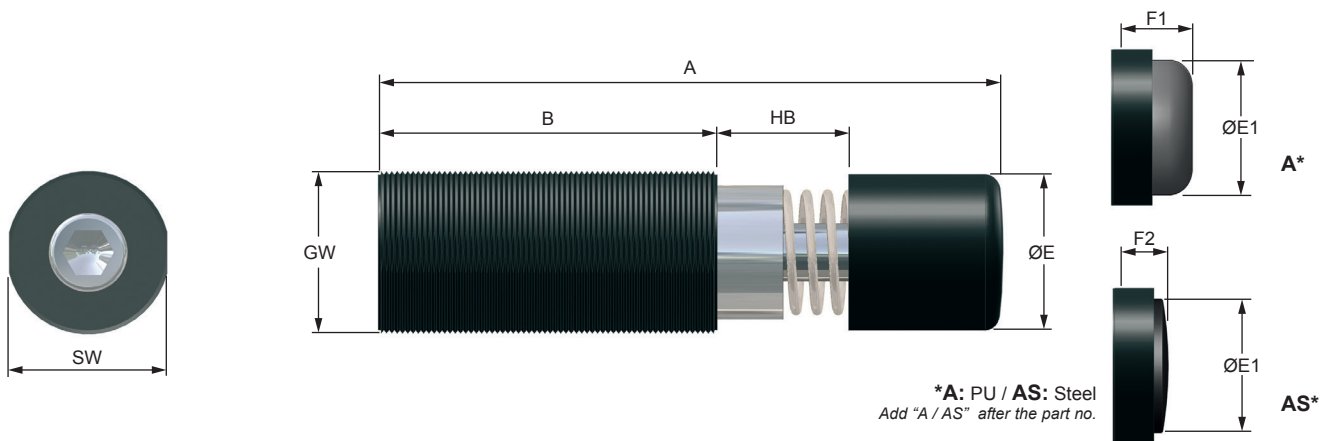

## DIMENSIONS

	GW*	A	B	Ø E	Ø E1	F1	F2	SW
		mm	mm	mm	mm	mm	mm	mm
WS-M 2,0 x 1	M 62 x 2	186	104	59	49	25	14	60
WP-M 2,0 x 1	M 62 x 2	186	104	59	49	25	14	60
WS-M 2,0 x 2	M 62 x 2	236	129	59	49	25	14	60
WP-M 2,0 x 2	M 62 x 2	236	129	59	49	25	14	60
WS-M 2,0 x 4	M 62 x 2	336	179	59	49	25	14	60
WP-M 2,0 x 4	M 62 x 2	336	179	59	49	25	14	60
WS-M 2,0 x 6	M 62 x 2	453	246	59	49	25	14	60
WP-M 2,0 x 6	M 62 x 2	453	246	59	49	25	14	60

## SPECIAL THREAD - from stock

Series	Code	Threads	Example
2,0	L	M 64x2	WS-M 2,0x1-1 L
2,0	U	2 1/2-12 UNF	WP-M 2,0x1-1 U

## STAINLESS STEEL - from stock

Series	Code	Threads	Example
2,0X1		M 62x2	WS-M 2,0X1-1-VA
2,0X1	L	M 64x2	WP-M 2,0X1-1L-VA
2,0X1	U	2 1/2-12 UNF	WS-M 2,0X1-1U-VA
2,0X2		M 62x2	WP-M 2,0X2-1-VA
2,0X2	L	M 64x2	WS-M 2,0X2-1L-VA
2,0X2	U	2 1/2-12 UNF	WP-M 2,0X2-1U-VA
2,0X4		M 62x2	WS-M 2,0X4-1-VA
2,0X4	L	M 64x2	WP-M 2,0X4-1L-VA
2,0X4	U	2 1/2-12 UNF	WS-M 2,0X4-1U-VA
2,0x6		M 62x2	WP-M 2,0X6-1-VA
2,0x6	L	M 64x2	WS-M 2,0X6-1L-VA
2,0x6	U	2 1/2-12 UNF	WP-M 2,0X6-1U-VA

## PERFORMANCE

	Stroke mm	Energy absorption			Effective mass				
		Constant load*	Nm/h (max.)	External tank** Nm/h	-0 (very soft)	-1 (soft)	-2 (medium)	-3 (hard)	-4 (very hard)
					min. - max. kg	min. - max.kg	min. - max.kg	min. - max.kg	min. - max.kg
WS-M 2,0 x 1	25	1.500	150.000	240.000	31 - 197	170 - 830	480 - 3.700	3.000 - 14.100	12.000 - 75.000
WP-M 2,0 x 1	25	1.500	150.000	240.000	-	31 - 187	150 - 1.330	1.030 - 8.300	-
WS-M 2,0 x 2	50	2.500	250.000	400.000	52 - 330	280 - 1.385	800 - 6.150	5.000 - 23.500	20.000 - 125.000
WP-M 2,0 x 2	50	2.500	250.000	400.000	-	52 - 310	250 - 2.200	1.730 - 13.800	-
WS-M 2,0 x 4	100	5.000	350.000	525.000	104 - 650	565 - 2.770	1.600 - 12.350	10.000 - 47.200	40.000 - 250.000
WP-M 2,0 x 4	100	5.000	350.000	525.000	-	100 - 625	490 - 4.400	3.460 - 27.700	-
WS-M 2,0 x 6	150	8.000	400.000	650.000	160 - 1.050	905 - 4.430	2.560 - 1.9750	16.000 - 75.500	64.000 - 400.000
WP-M 2,0 x 6	150	8.000	400.000	650.000	-	160 - 1.000	790 - 7.100	5.530 - 44.000	-

Technical data at + 20°C

## Technical Data

<b>Weight</b>	<b>2,0 x 1:</b>	2,0 kg
	<b>2,0 x 2:</b>	3,0 kg
	<b>2,0 x 4:</b>	3,9 kg
	<b>2,0 x 6:</b>	4,8 kg
<b>Impact speed</b>	<b>WS-M:</b>	0,10 - 6,0 m/s
	<b>WP-M:</b>	0,40 - 8,0 m/s
<b>Return spring force</b>	<b>2,0 x 1 :</b>	50 N/min - 130 N/max
	<b>2,0 x 2 :</b>	40 N/min - 130 N/max
	<b>2,0 x 4 :</b>	45 N/min - 130 N/max
	<b>2,0 x 6 :</b>	35 N/min - 130 N/max
<b>Torque:</b>	<b>2,0 :</b>	40 Nm
<b>Max. force by using the flats</b>		
<b>Housing</b>		Black finish
<b>Piston rod</b>		Hardened stainless steel
<b>RoHS - compliant</b>		Directive 2002/95/EG

## Accessories

### Lock nut

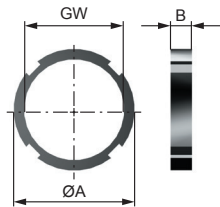

Art.-Nr.: S25012

GW	ØA mm	B mm	Code
M62x2	74	10	S25012
M64x2	74	10	S25012L
2 1/2-12UNF	74	10	S25012U
stainless steel			
M62x2	74	10	S25012VA
M64x2	74	10	S25012L-VA

### Stop limit nut

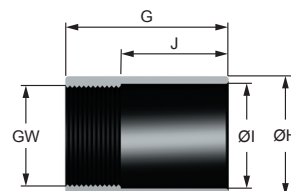

Art.-Nr.: S25018

GW	ØI mm	ØH mm	G mm	J mm	Code
M62x2	65	74	100	60	S25018
M64x2	65	74	100	60	S25018L
2 1/2-12UNF	65	74	100	60	S25018U

### Square flange

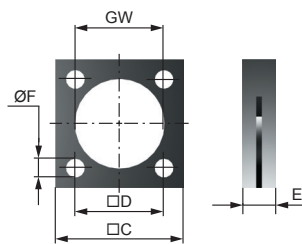

Art.-Nr.: S25014

GW	ØF mm	E mm	D mm	C mm	Code
M62x2	11	20	60	80	S25014
M64x2	11	16	58	80	S25014L
2 1/2-12UNF	11	20	58	80	S25014U
stainless steel					
M62x2	11	20	60	80	S25014VA

### Foot mounting

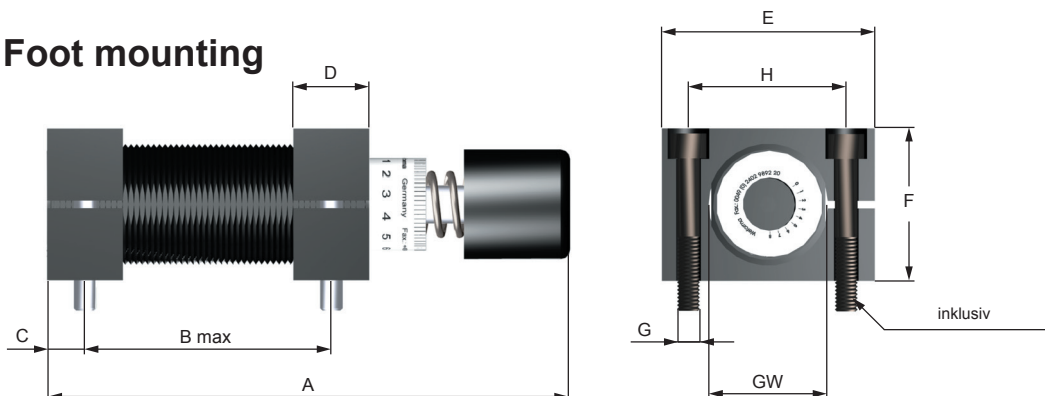

	GW*	A	B max	C	D	E	F	G	H	Code
	Standard	mm	mm	mm	mm	mm	mm	mm	mm	
2,0 x 1	M62 x 2	186	79	12,5	25	100	80	M10x80	76	S25015
2,0 x 2	M62 x 2	236	104	12,5	25	100	80	M10x80	76	S25015
2,0 x 4	M62 x 2	336	154	12,5	25	100	80	M10x80	76	S25015
2,0 x 6	M62 x 2	453	221	12,5	25	100	80	M10x80	76	S25015
2,0 x 1L	M64 x 2	186	79	12,5	25	100	80	M10x80	78	S25015L
2,0 x 2L	M64 x 2	236	104	12,5	25	100	80	M10x80	78	S25015L
2,0 x 4L	M64 x 2	336	154	12,5	25	100	80	M10x80	78	S25015L
2,0 x 6L	M64 x 2	453	221	12,5	25	100	80	M10x80	78	S25015L

## Clevis mounting

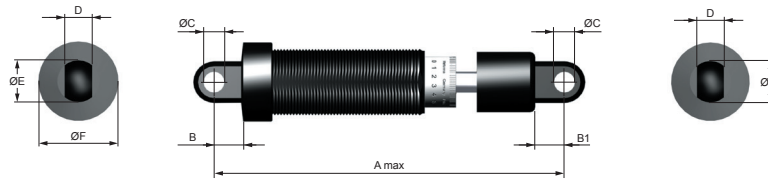

Code.: S25016

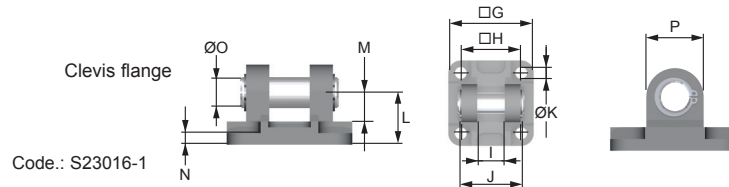

Clevis flange

Code.: S23016-1

Pull: End stop required 1 mm before the stroke ends

Standard: Shock absorber with clevis mounting is delivered without return spring.  
Return spring is available on request.

	GW*	A max	B	B1	Ø C	D	Ø E	Ø F	G	H	I	J	Ø K	L	M	N	Ø O	P
		mm	mm	mm	mm	mm	mm	mm	mm	mm	mm	mm	mm	mm	mm	mm	mm	mm
2,0 x 1	M62 x 2	272	35	35	20	24	40	74	95	72	25	65	11	36	22	10	20	42
2,0 x 2	M62 x 2	322	35	35	20	24	40	74	95	72	25	65	11	36	22	10	20	42
2,0 x 4	M62 x 2	422	35	35	20	24	40	74	95	72	25	65	11	36	22	10	20	42
2,0 x 6	M62 x 2	539	35	35	20	24	40	74	95	72	25	65	11	36	22	10	20	42
2,0 x 1L	M64 x 2	272	35	35	20	24	40	74	95	72	25	65	11	36	22	10	20	42
2,0 x 2L	M64 x 2	322	35	35	20	24	40	74	95	72	25	65	11	36	22	10	20	42
2,0 x 4L	M64 x 2	422	35	35	20	24	40	74	95	72	25	65	11	36	22	10	20	42
2,0 x 6L	M64 x 2	539	35	35	20	24	40	74	95	72	25	65	11	36	22	10	20	42
2,0 x 1U	2 1/2-12UNF	272	35	35	20	24	40	74	95	72	25	65	11	36	22	10	20	42
2,0 x 2U	2 1/2-12UNF	322	35	35	20	24	40	74	95	72	25	65	11	36	22	10	20	42
2,0 x 4U	2 1/2-12UNF	422	35	35	20	24	40	74	95	72	25	65	11	36	22	10	20	42
2,0 x 6U	2 1/2-12UNF	539	35	35	20	24	40	74	95	72	25	65	11	36	22	10	20	42

## Accessories

### Protection bellow

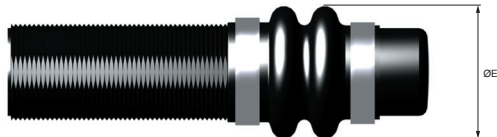

	$\varnothing E$ mm	Code
2,0 x 1	90	S25517
2,0 x 2	90	S25017
2,0 x 4	90	S25117
2,0 x 6	90	S25217

### AK 1

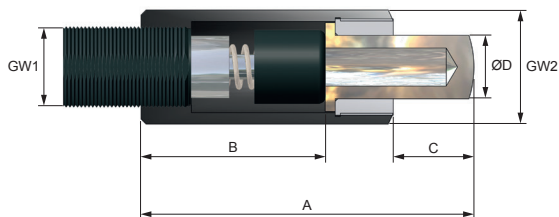

	GW1	GW2	A	B	C	$\varnothing D$	Code
			mm	mm	mm	mm	
2,0 x 1	M62x2	M85x2	158,5	102	29,5	55	S25019
2,0 x 2	M62x2	M85x2	208,5	127	54,5	55	S25119
2,0 x 1L	M64x2	M85x2	158,5	102	29,5	55	S25119L
2,0 x 2L	M64x2	M85x2	208,5	127	54,5	55	S25119L

## External Tanks

### AT 2

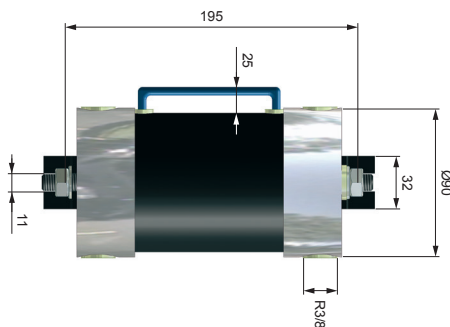

### WE-M 2,0 x 2 - 1AT

For shock absorbers without return spring

### WE-M 2,0 x 2 - 1 ATF

For shock absorbers with return spring

### WM-AT 1

For external Tanks

Code.: 23820

WS-M 2,0

### Benefits:

Optimum cooling and therefore higher energy absorption per hour"

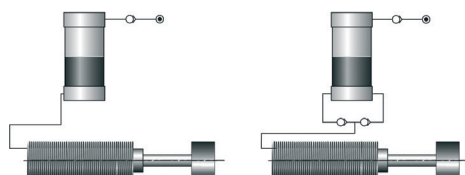

## Adjustment

The shock absorbers Mega-Line 2,0 are self-adjusting.

Damping characteristics:

WS-M - self-adjusting, linear

WP-M - self-adjusting, progressively

The attenuation factor are available by default:

- 0 - very soft
- 1 - soft
- 2 - medium
- 3 - hard
- 4 - very hard

The damping level is calculated with the formula for the effective mass. (see calculation in the catalog)

If the mass in a trial run impacts excessively hard on the fixed stop select the next harder model. If the mass impacts too hard on the shock absorber choose a softer version.

## Installation

### Foot mounting

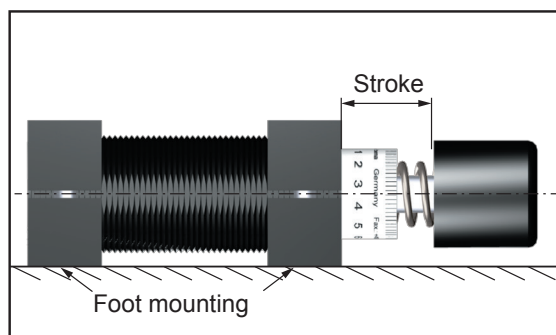

### Clevis mounting

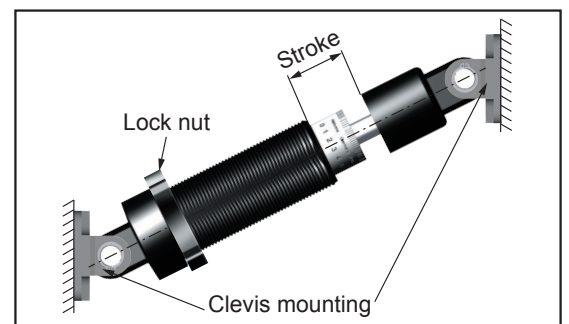

### Installation with stop limit nut

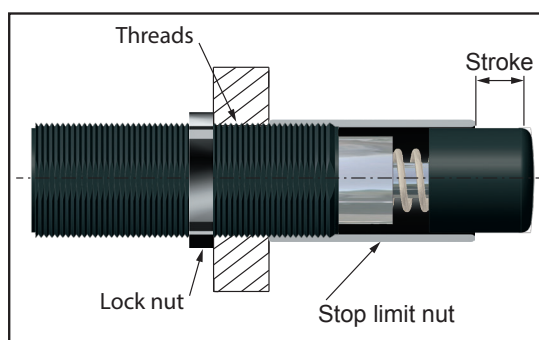

### Installation with flange

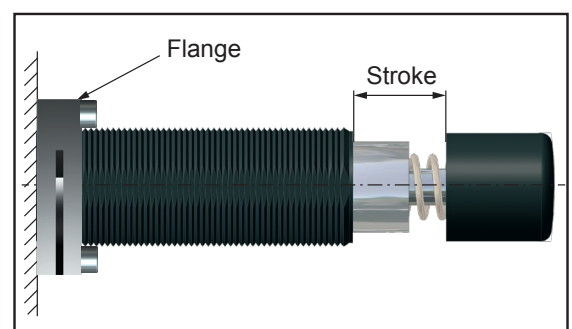



## Safety Instructions

Before installation, commissioning, servicing and repair the data sheet is to be noticed. This work may only be performed by trained, introduced staff.

Electric connections according to the suitable national regulation. For Germany: VDE regulation VD E0100

Before all repair and servicing works the energy supplies (main switch, etc.) have to be switched off! Moreover, measures are necessary to prevent an unintentional reconnect. For example, a warning sign "service works" or "maintenance work", applied to the switch.

## Designated use

Check before installation and make sure the type name on the shock absorber or on the packaging is corresponding with delivery note. Industrial shock absorbers are maintenance-free and ready for installation.

- Temperature influence: at higher temperatures the shock absorber characteristic will change.
- Movable loads have to be protected during the installation and maintenance against unintentional processes.
- In operation outside the allowed temperature range, the shock absorber can lose his function. Due to heat radiation don't paint the shock absorber.
- Fluids, gases and a dirty environment can affect or destroy the sealing system of the shock absorber. The result could be a failure malfunction. Piston rod and sealing system has to be protected against fluids, gases and a dirty environment.
- Damages at the piston rod can destroy the sealing system. Don't grease or oil the piston rod.
- Avoid traction forces on the piston rod to present internal damages.
- The shock absorber can be pulled out of the construction during the impact. The construction needs to be able to resist the max counterforce. Sufficient security must be calculated.  
The maximum counterforces performed in the calculation program can vary from the really appearing counter forces, because these are based on theoretical values.

## Fundamentals

Shock absorbers may under no circumstances be:

-painted



-welded



-held with clamps



-used on pull\*



(exception: clevis mounting)

In hazardous environments (dirt, humidity, oil) shock absorbers must be protected against damage and failure with the necessary accessory. If several shock absorbers are used on the same application, the deceleration has to be distributed equally. The "Torque" (PERFORMANCE) indicates the maximum force by using the flats. The Weforma catalogue shows technical data with both minimum and maximum values. If a product is to be used in continuous operation and within a range of 20% from the minimum and maximum values shown, then written confirmation of suitability of use from Weforma is necessary.

## Important information

### Integrated end-stop

Up to the Mega-Line series 2,0 the shock absorbers are provided with an integrated end-stop. If the integrated end-stop is used the remaining energy before end of stroke must not be higher than 10% of the total energy. For all models which are used as an emergency stop an external fixed stop is necessary.

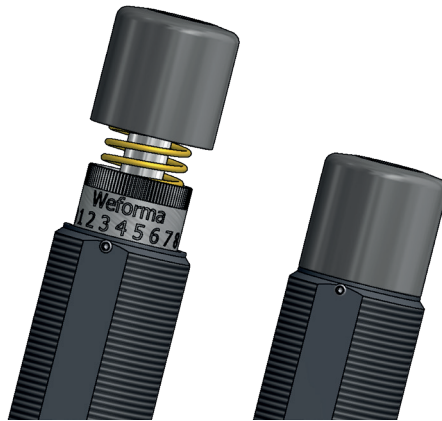

### Installation situation

The installation situation is any, however always in such a way that the complete shock absorber stroke can be used. The shock absorbers must be mounted like that the forces in centerline about the piston rod are initiated. The maximum angle out of centre amounts to 2 °.

### Liability

Due to the number of possible uses of our products and the conditions of use that lie outside of our scope of influence, we accept no liability as to whether the purchase object is suitable for the Client's intended purpose. The verification to this effect, in particular the verification as to whether the purchase object is suitable for the planned use, is the responsibility of the Client alone, unless expressly agreed otherwise in writing.

For the reasons we accept no liability for the suitability of the purchase object for the purpose intended by the Client, except in cases of intent or gross negligence.

With damages, the not designated use and from high-handed, in these instructions do not originate to intended interventions, any guarantee and liability claim goes out towards the manufacturer.

### Guarantee

By non-use of the original spare parts the guarantee claim goes out.

### Environment protection

By the exchange from damaged parts is to be respected to a proper disposal.