

Double-Acting Speed Control

WM-VD 80

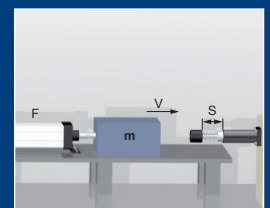

ONLINE
Calculation and
2D / 3D CAD Download



Features

Extended Life Time:

- Special Seals + Oils

Material:

- Housing: anodised aluminium
- Piston rod hard-chrome plated

Temperature:

- Standard: -20°C-+80°C
- Low-temperature: -50°C - +60°C
- High-temperature: 0°C - +120°C

RoHS-conform:

- Directive 2002/95/EC

Adjustment:

- Precise adjustment in Push- and Pull direction
- Continuous adjustment over the entire stroke

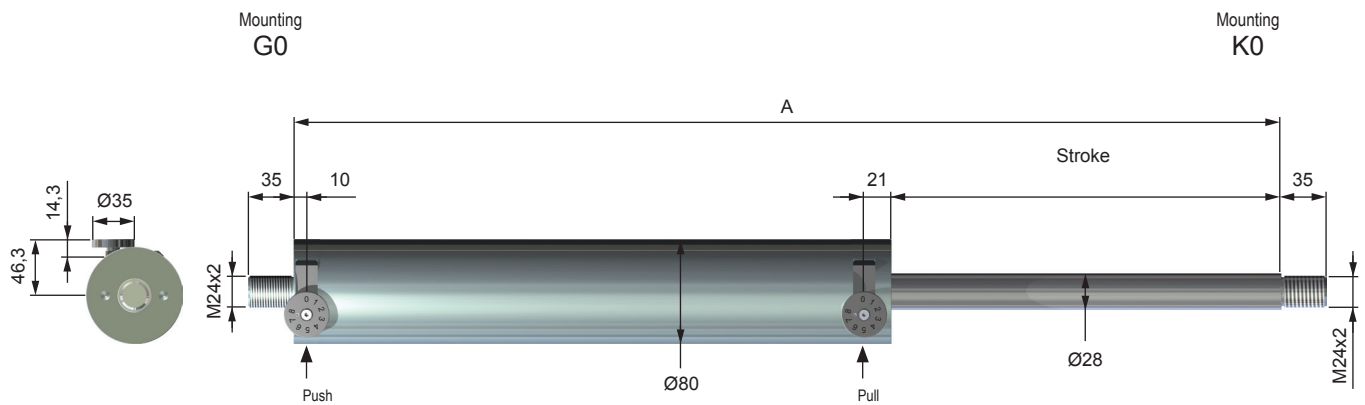

PERFORMANCE

	Stroke	Pull	Push	Pull - Push	Speed rates	A	Weight
	mm	N max.	N max.	N min.	m/min	mm	kg
WM-VD 80 - 100	100	20.000	20.000	150	0,05 - 40	360	7,0
WM-VD 80 - 150	150	20.000	20.000	150	0,05 - 40	460	8,3
WM-VD 80 - 200	200	20.000	20.000	150	0,05 - 40	560	9,6
WM-VD 80 - 250	250	20.000	20.000	150	0,05 - 40	660	10,9
WM-VD 80 - 300	300	20.000	20.000	150	0,05 - 40	760	12,15
WM-VD 80 - 400	400	20.000	15.000	150	0,05 - 40	960	14,71
WM-VD 80 - 500	500	20.000	15.000	150	0,05 - 40	1160	17,27

Accessories

3 Female rod clevis (DIN 71752)

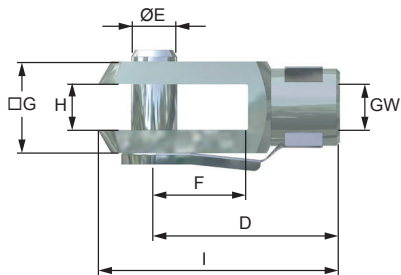

4 Spherical end bearing (DIN 648, Series K)

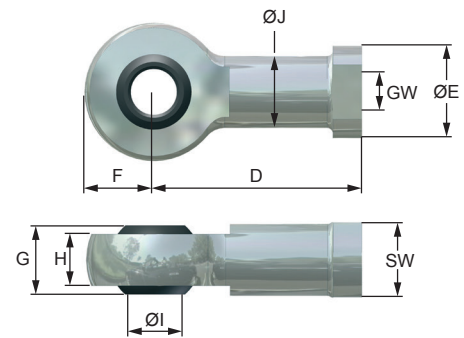

5 Clevis flange only use in combination with spherical end bearing (4)

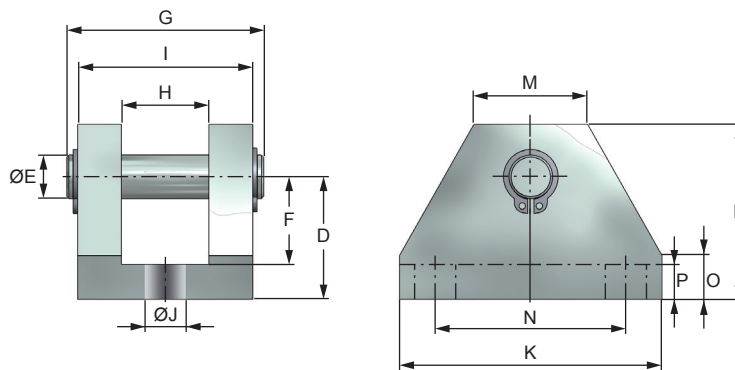

DIMENSIONS

	GW*	D	ØE	F	G	H	I	J	SW	K	L	M	N	O	P	
																mm
3	WM-Z 7	M 24 x 2	100	25	50	50	25	132	-	-	-	-	-	-	-	
4	WM-Z 7	M 24 x 2	94	42	30	31	22	25	33,5	36	-	-	-	-	-	
5	WM-Z 7	M 24 x 2	45	25	33	70	32	65	13	-	90	65	40	70	20	12

Ordering Information	
WM-VD 80-100-K3G4-C	
WM	Weforma
VD	Speed control, double-acting
80	Size
100	Stroke
K3	Piston rod - Female rod clevis
G4	Housing - Spherical end bearing
C	Type of deceleration: A=Push, B=Pull, C=Push und Pull

Setting

The Speed rate is stopped in the adjusting screw at the of the shock absorber.

Set possibility on the scale 0-8

0 = high Speed rate

8 = low Speed rate



Important Information

Safety Instructions

Before Installation, commissioning, servicing and repair the data sheet is to be noticed. This work may only be performed by trained, introduced staff.

Electric connections according to the suitable national regulation.
For Germany: VDE regulation VD E0100

Before all repair and servicing works the energy supplies (main switch, etc.) have to be switched off! Moreover, measures are necessary to prevent an unintentional reconnect.
For example, a warning sign „service works“ or „maintenance work“, applied to the switch.

Designated use

Check before installation and make sure the type name on the speed control or on the packaging is corresponding with delivery note.

Speed control are maintenance-free and ready for installation.

- Temperature influence: at higher temperatures the speed control characteristic will change.
- Movable loads have to be protected during the installation and maintenance against unintentional processes.
- In operation outside the allowed temperature range, the speed control can lose his function. Due to heat radiation don't paint the speed control.
- Fluids, gases and a dirty environment can affect or destroy the sealing system of the shock absorber. The result could be a failure malfunction. Piston rod and sealing system has to be protected against fluids, gases and a dirty environment.
- Damages at the piston rod can destroy the sealing system. Don't grease or oil the piston rod.
- Avoid traction forces on the piston rod to present internal damages.
- The speed control can be pulled out of the construction during the impact. The construction needs to be able to resist the max counterforce. Sufficient security must be calculated.
- A fixed stop must be set in the end positions 1 - 1,5 mm before the end of the stroke.

Important Information

Basic information

Speed control may under no circumstances be:

-painted



-welded



-held with clamps



In hazardous environments (dirt, humidity, oil) speed control must be protected against damage and failure with the necessary accessory. If several Speed control are used on the same application, the deceleration has to be distributed equally. The Weforma catalogue shows technical data with both minimum and maximum values. If a product is to be used in continuous operation and within a range of 20% from the minimum and maximum values shown, then written confirmation of suitability of use from Weforma is necessary.

Installation situation

The installation situation is any, however always in such a way that the complete speed control stroke can be used. The speed control must be mounted like that the forces in centerline about the piston rod are initiated. The maximum angle out of centre amounts to 2°.

Liability

Due to the number of possible uses of our products and the conditions of use that lie outside of our scope of influence, we accept no liability as to whether the purchase object is suitable for the Client's intended purpose. The verification to this effect, in particular the verification as to whether the purchase object is suitable for the planned use, is the responsibility of the Client alone, unless expressly agreed otherwise in writing.

For the reasons we accept no liability for the suitability of the purchase object for the purpose intended by the Client, except in cases of intent or gross negligence.

With damages, the not designated use and from high-handed, in these instructions do not originate to intended interventions, any guarantee and liability claim goes out towards the manufacturer.

Guarantee

By non-use of the original spare parts the guarantee claim goes out.

Environment protection

By the exchange from damaged parts is to be respected to a proper disposal.