

Rotary Dampers

with high-torque range

WRD-H 7550

WRD-H 9565

WRD-H 12070



ONLINE
CALCULATION AND
2D / 3D CAD DOWNLOAD

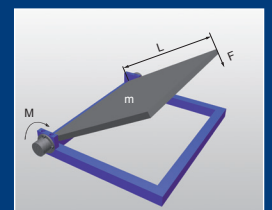

Benefits

Material:

- Aluminium and steel

Applications:

- Mechanical and plant engineering
- Vendingmachines, Counters
- Car industry and sanitary industry

RoHS-conform:

- Directive 2002/95/EC

Temperature:

- Standard: -10°C - +60°C

Deceleration:

- Controlled damping with rotary movements
- Torques up to 700 Nm
- Both sides, Right-turning and left-turning
- Adjustable

Special model:

Stainless steel VA:

- Housing Stainless steel V2A / DIN 1.4305 / AISI 303
- Piston rod DIN 1.4125 / AISI 440C

Applications:

- Food industry, Outside machinery, Medical technology



R (CW)*	L (CCW)*	C*	M* max. (Nm)	M* min. (Nm)	Material*
WRD-H 7550-R	WRD-H 7550-L	WRD-H 7550-C	250	65	Steel
WRD-H 9565-R	WRD-H 9565-L	WRD-H 9565-C	500	140	
WRD-H 12070-R	WRD-H 12070-L	WRD-H 12070-C	700	270	

	ØA	ØB	ØC	D	E	F	G	H	I	J	ØK	L	X
WRD-H 7550	90	25	130	100	10	25	140	6,4	28	8	8,2	110,0	6
WRD-H 9565	120	30	155	125	15	32	175	9,0	33	10	8,2	137,5	6
WRD-H 12070	148	35	188	155	15	45	215	10,0	38	10	10,5	168,0	4

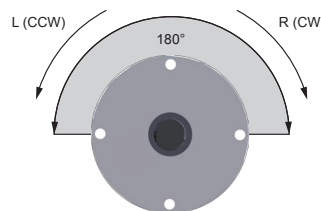
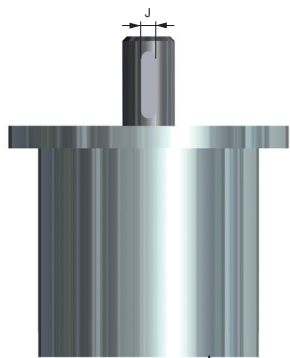
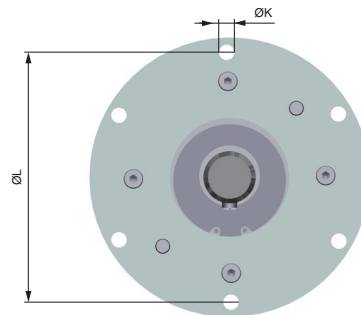
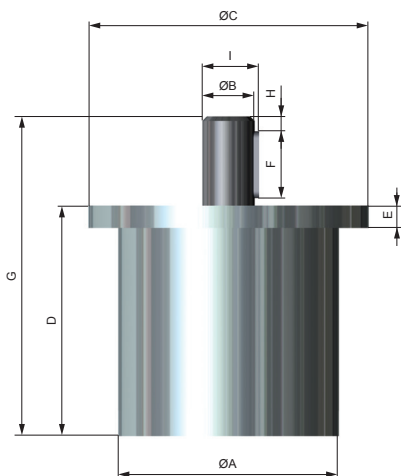

* R (CW): Clockwise
 L (CCW): Anti-clockwise
 C: Clockwise and anticlockwise
 M: Torque
 Material

Stainless steel - from stock

Clockwise	Anti-clockwise	Clockwise and anti-clockwise	Torque
			Nm
WRD-H 7550-R-VA	WRD-H 7550-L-VA	WRD-H 7550-C-VA	250
WRD-H 9565-R-VA	WRD-H 9565-L-VA	WRD-H 9565-C-VA	500
WRD-H 12070-R-VA	WRD-H 12070-L-VA	WRD-H 12070-C-VA	700

TORQUE

Clockwise	Anti-clockwise	Clockwise and anti-clockwise	Torque	Opening angle	Weight
			Nm	°	g
WRD-H 7550-R	WRD-H 7550-L	WRD-H 7550-C	250	180	4500
WRD-H 9565-R	WRD-H 9565-L	WRD-H 9565-C	500	180	10000
WRD-H 12070-R	WRD-H 12070-L	WRD-H 12070-C	700	180	17400

Idle: At the beginning of the deceleration max. 5°

Important Information

Rotary dampers can not be used as end stop; external stop must be provided before the end of the stroke.

Temperature

WRD-H: -10 °C - +60 °C

Reference temperature for all technical information: 20°C

At a higher temperatures the energy absorption or torque is reduced.

Fix the rotary damper at the intended bores and flats. It is not allowed to loaded rotary dampers in a static way or to fix them by welding.

Rotary damper can not be used with aggressive fluids. Exception WRD-H...VA

Adjustment

If the mass in a trial run impacts excessively hard on the end position select the next model with higher torque for the series

Rotary dampers of the series WRD-H 7550, 9565 and 12070 are adjustable. If the damping is not sufficient, increase the damping continuously by rotating the adjustment to „+“.

If the mass don't reach the end position or the time is too long, decrease the damping continuously by rotating the adjustment to „-“. If the adjustment is not sufficient in an end position contact Weforma.

Rotary dampers should under no circumstance be loaded over the damping angle mentioned in the catalogue.

Fundamentals

Rotary dampers may under no circumstances be:

-painted



-welded



-held with clamps



The products must be protected against contamination, fluids and air pressure. We offer special solutions for these applications. When rotary dampers are used parallel the size of the model and the used degree of hardness / used adjustment has to be the same. The load has to be distributed equally. When a shock absorber is used for an emergency case, an external end stop must be provided. If the absorption should be insufficient, please contact Weforma or the respective representation. You will find further technical informations to the series in our catalogue.

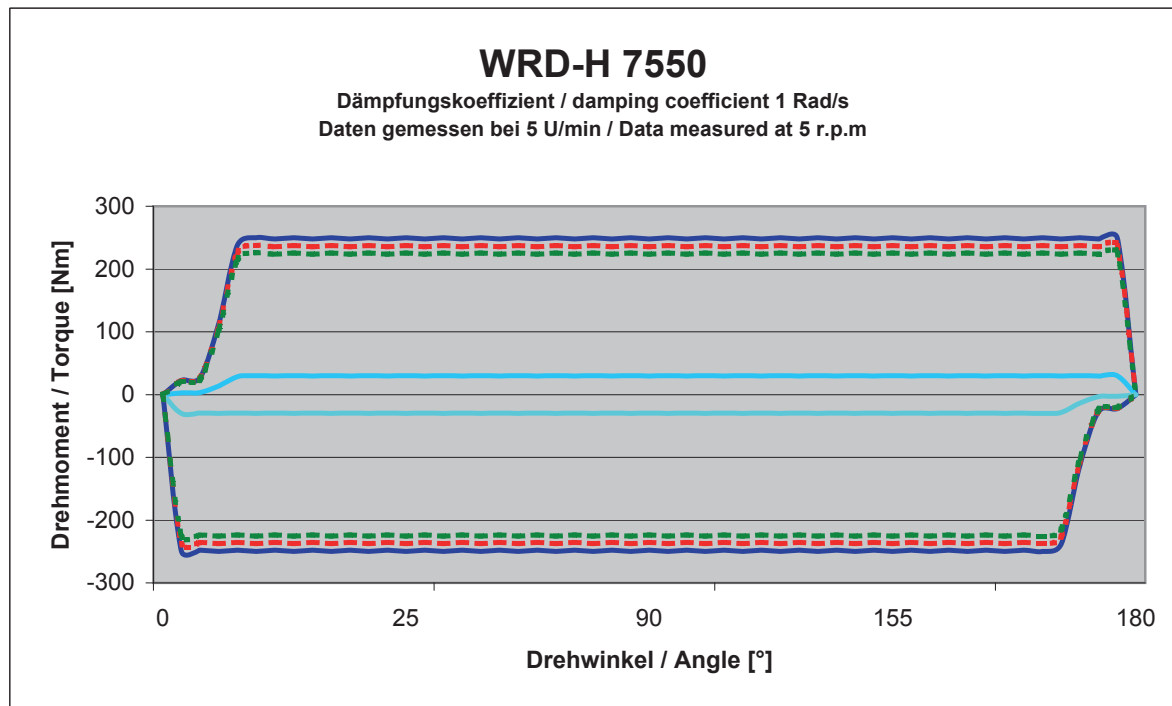

- Ausführung WRD-H 7550 C maximale Dämpfung in beide Richtungen bei 20° C
 Execution WRD-H 7550 C maximum damping in both directions at 20 ° C

- Ausführung WRD-H 7550 C maximale Dämpfung in beide Richtungen bei 40° C
 Execution WRD-H 7550 C maximum damping in both directions at 40 ° C

- Ausführung WRD-H 7550 C maximale Dämpfung in beide Richtungen bei 60° C
 Execution WRD-H 7550 C maximum damping in both directions at 60 ° C

- Ausführung WRD-H 7550 R maximale Rücklaufdämpfung bei 20° C
 Execution WRD-H 7550 R maximum returndamping at 20 ° C

- Ausführung WRD-H 7550 L maximale Rücklaufdämpfung bei 20° C
 Execution WRD-H 7550 L maximum returndamping at 20 ° C

maximaler Drehwinkel 180° / maximum angle 180°

Ausführung "R" und "L" jeweils nur in eine Richtung / execution "R" and "L" only in one direction

Die Werte können in Abhängigkeit von der Einstellung und der Geschwindigkeit abweichen
 The values may vary depending on the adjustment and the speed

Dieser Dämpfer ist einstellbar / this damper is adjustable

technische Änderungen vorbehalten / subject to technical changes

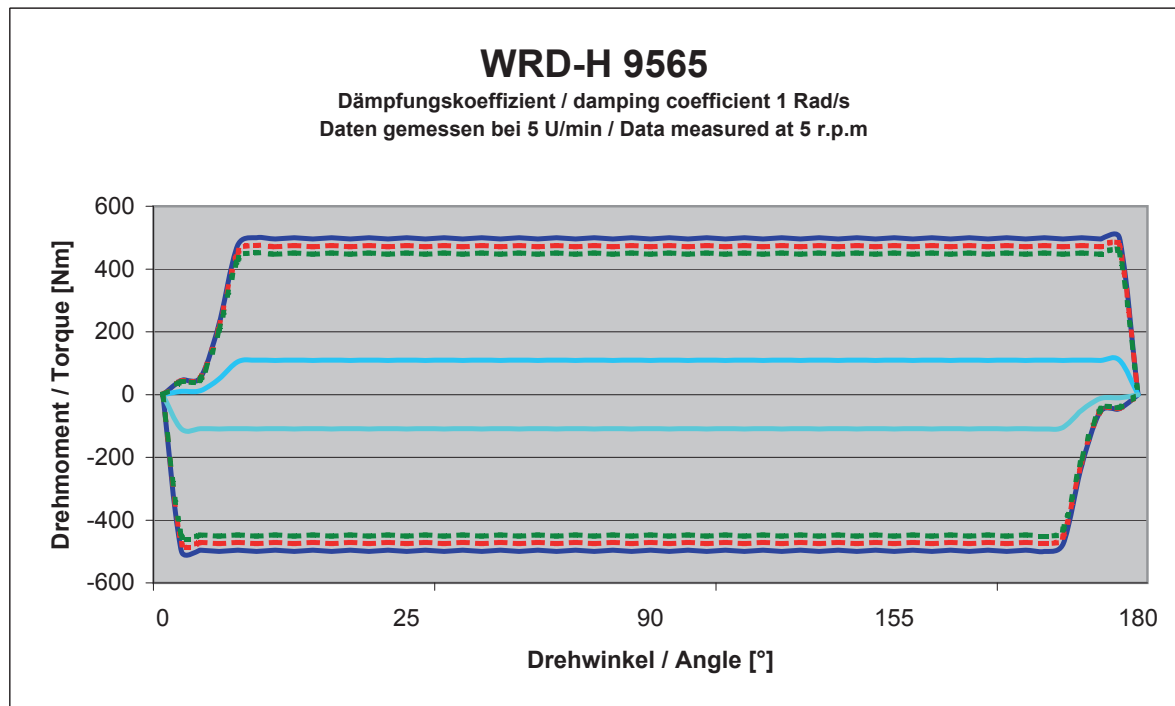

- Ausführung WRD-H 9565 C maximale Dämpfung in beide Richtungen bei 20° C
 Execution WRD-H 9565 C maximum damping in both directions at 20 ° C
- Ausführung WRD-H 9565 C maximale Dämpfung in beide Richtungen bei 40° C
 Execution WRD-H 9565 C maximum damping in both directions at 40 ° C
- Ausführung WRD-H 9565 C maximale Dämpfung in beide Richtungen bei 60° C
 Execution WRD-H 9565 C maximum damping in both directions at 60 ° C
- Ausführung WRD-H 9565 R maximale Rücklaufdämpfung bei 20° C
 Execution WRD-H 9565 R maximum returndamping at 20 ° C
- Ausführung WRD-H 9565 L maximale Rücklaufdämpfung bei 20° C
 Execution WRD-H 9565 L maximum returndamping at 20 ° C

maximaler Drehwinkel 180° / maximum angle 180°

Ausführung "R" und "L" jeweils nur in eine Richtung / execution "R" and "L" only in one direction

Die Werte können in Abhängigkeit von der Einstellung und der Geschwindigkeit abweichen
 The values may vary depending on the adjustment and the speed

Dieser Dämpfer ist einstellbar / this damper is adjustable

technische Änderungen vorbehalten / subject to technical changes

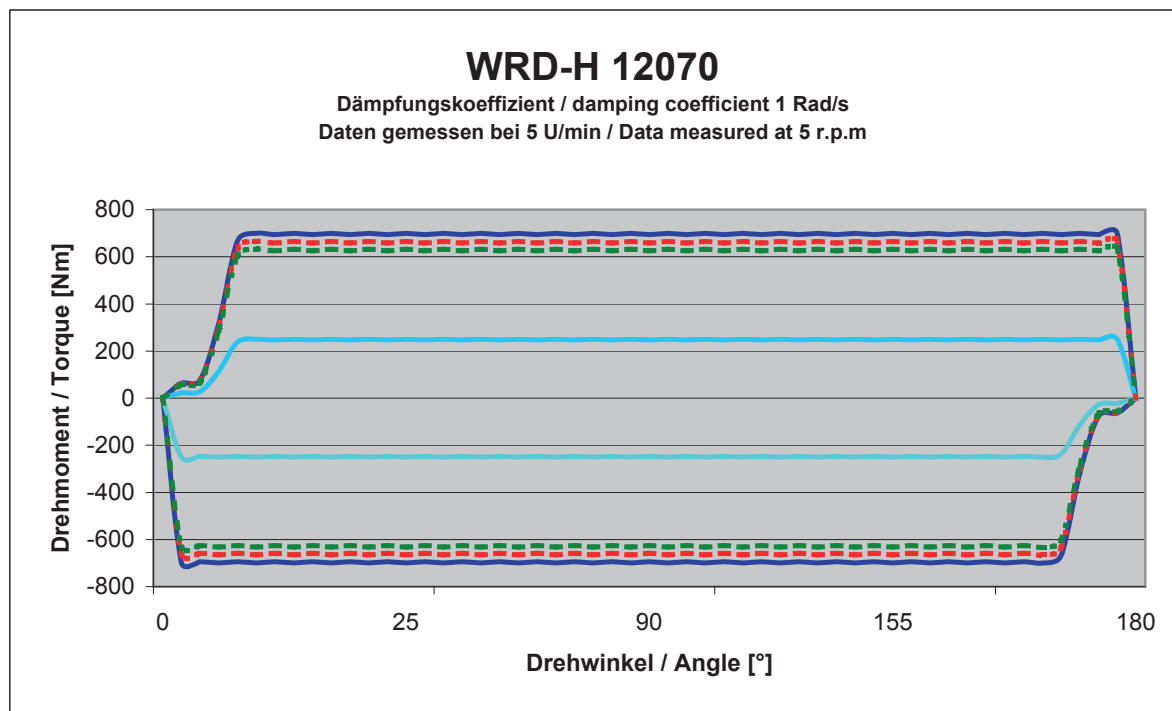

- Ausführung WRD-H 12070 C maximale Dämpfung in beide Richtungen bei 20° C
 Execution WRD-H 12070 C maximum damping in both directions at 20 ° C
- Ausführung WRD-H 12070 C maximale Dämpfung in beide Richtungen bei 40° C
 Execution WRD-H 12070 C maximum damping in both directions at 40 ° C
- Ausführung WRD-H 12070 C maximale Dämpfung in beide Richtungen bei 60° C
 Execution WRD-H 12070 C maximum damping in both directions at 60 ° C
- Ausführung WRD-H 12070 R maximale Rücklaufdämpfung bei 20° C
 Execution WRD-H 12070 R maximum returndamping at 20 ° C
- Ausführung WRD-H 12070 L maximale Rücklaufdämpfung bei 20° C
 Execution WRD-H 12070 L maximum returndamping at 20 ° C

maximaler Drehwinkel 180° / maximum angle 180°

Ausführung "R" und "L" jeweils nur in eine Richtung / execution "R" and "L" only in one direction

Die Werte können in Abhängigkeit von der Einstellung und der Geschwindigkeit abweichen
 The values may vary depending on the adjustment and the speed

Dieser Dämpfer ist einstellbar / this damper is adjustable

technische Änderungen vorbehalten / subject to technical changes